

A.B. Tools, Inc.

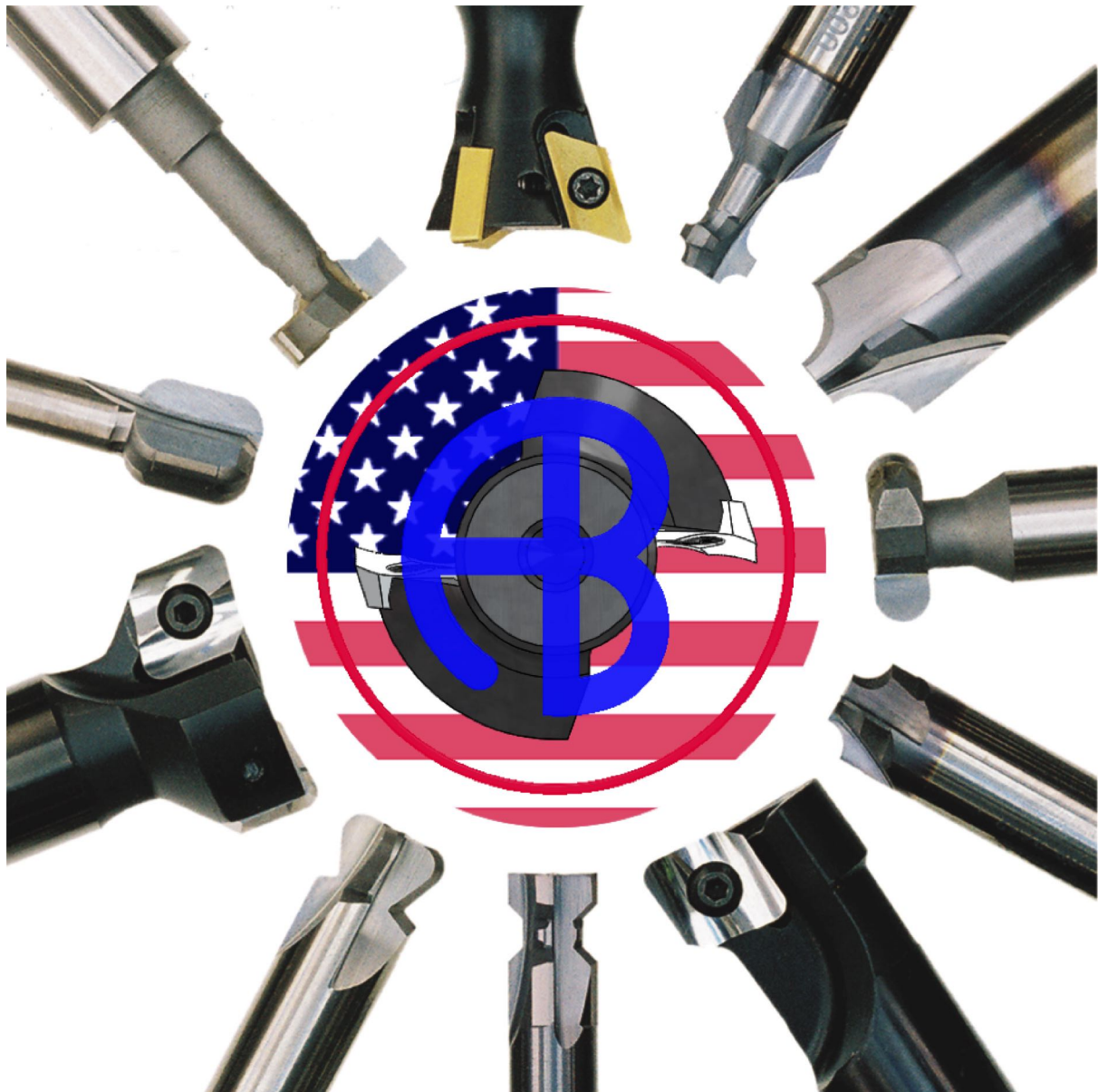

Made in the USA since 1977

1051 Aviation Blvd.
Lincoln, CA 95648-9312
(916) 408-2442 FAX (916) 408-0740
Toll free phone (866) 440-8665
www.abtoolsinc.com
E-Mail: mail@abtoolsinc.com

New Products →

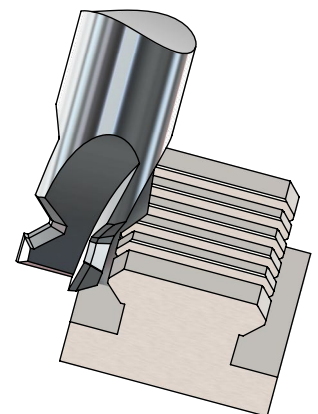
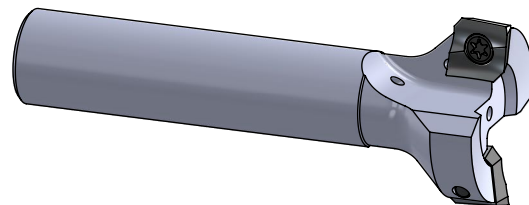
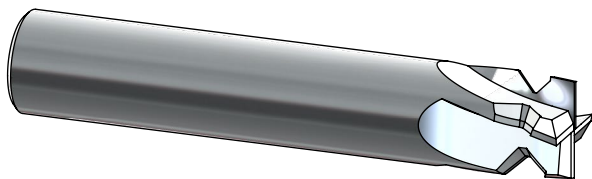

Table of Contents

Page	Description	Page	Description
1.	Table of Contents	28.	Extra Long Corner Rounders, Solid carbide
2.	Keyseat Cutters, Carbide Tipped	29.	Thread Mills, Solid Carbide
3.	Keyseat Cutters, Extra Long, Carbide Tipped	30.	Thread Relief Mills, Solid Carbide - New
4.	Keyseat Cutters, Smaller Dia., Solid Carbide	31.	Bevel Cutters, Solid Carbide
5.	Keyseat Cutters, Larger Dia., Solid Carbide	32.	Top and Bottom Chamfer Cutters - New
6.	Keyway Cutters, Standard, Solid Carbide - New	33.	Chamfer End Mills, Solid Carbide - New
7.	Keyway Cutters, Standard, Carbide Tipped - New	34.	Taper End Mills, Solid Carbide - New
8.	Picatinny Rail Cutters - New	35.	Angle Reference
9.	Male (fixture) Picatinny Cutters - New	36.	Dovetail Cutters, Carbide Tipped
10.	Picatinny Slot & Chamfer End Mill - New	37.	Dexi-Dovetails, 10° to 60°, with Short Insert
11.	Keymod Cutter - New	38.	Dexi-Dovetails, 20° to 60°, with Long Insert
12.	Charging Handle Slot Cutter - New	39.	Dexi-Dovetails, 70° to 90°, with Original Insert
13.	O-Ring Dovetail Cutters, Inch	40.	Dexi-Dovetails, 70° to 90°, with Wide Insert - New
14.	O-Ring Dovetail Cutters, Metric	41.	Chamfer Hogs, Positive Rake
15.	O-Ring Dovetail Cutters, Without Drop Hole - New	42.	Chamfer Hogs, Negative Rake
16.	O-Ring Dovetail Cutters, Half Dovetail - New	43.	Chamfer Hogs, Single Flute
17.	O-Ring Dovetail Lathe Tools	44.	Spot-Dex Tools
18.	O-Ring Dovetail Cutters, Special Quote Form	45.	Weldon / Linear Flat Tools
19.	Cable Groove Dovetail Cutters - New	46.	Saw Arbors
20.	Dovetail Cutters, Solid Carbide, 1/8"Ø to 1/4"Ø - New	47.	Accu-Holds, Inch
21.	Dovetail Cutters, Solid Carbide, 3/8"Ø to 5/8"Ø - New	48.	Accu-Holds, Metric
22.	Corner Rounders, Solid Carbide (smaller radii)	49.	Accu-Bores, Weldon Flats Specs, Mat'l Removal
23.	Corner Rounders, Carbide Tipped (med. radii)	50.	Aluminum Milling Tests
24.	Corner Rounders, HSS Cobalt (large radii)	51.	Aluma-Hogs
25.	Top and Bottom Corner Rounders	52.	Shear-Hogs, Shell
26.	Back Corner Rounders - New	53.	Shear-Hogs, T-Slot
27.	Full Concave Radius Cutters	54.	Shear-Hogs, Single Flute
		55.	Shear-Hogs, Multi Flute (Back Cover)



Phone 916 408-2442 FAX 916 408-0740

Toll free phone 866 440-8665



A. B. TOOLS, INC.
1051 Aviation Blvd.
Lincoln, CA, 95648-9312

If any product is not satisfactory
we will modify, replace or refund.

www.abtoolsinc.com
E-Mail: mail@abtoolsinc.com

Carbide Tipped Keyseat Cutters with your decimal width in 4-6 working days

Machining what part material, please? _____

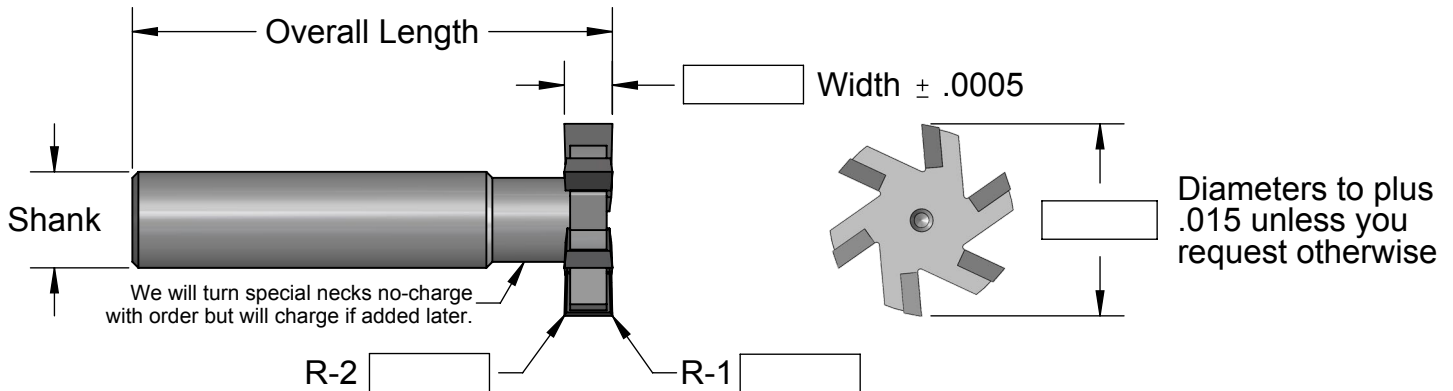

Diameter Plus .015 Minus Zero	Width Range	Basic Cutter Prices				Shank & Overall Length
		For Aluminum Flutes	Price	For Ferrous Flutes	Price	
5/8	.065/.190	2	\$90.	5	\$115.	1/2 Shank 2.5 OAL
3/4	.065/.220	2	\$95.	5	\$115.	
7/8	.075/.255	2	\$105.	6	\$120.	
1	.085/.315	2	\$110.	6	\$125.	
1-1/8	.110/.315	2	\$110.	6	\$140.	
1-1/4	.110/.350	3	\$115.	8	\$155.	
1-3/8	.110/.380	3	\$125.	8	\$160.	

For Minor Modifications add to your basic price:

1 CHAMFER \$35.
2 CHAMFERS \$50.

1 RADIUS \$40.
2 RADII \$60.
FULL RADIUS \$60.

Staggered tooth cutters add 30% to basic price
(2) piece minimum

Slot plus topping chamfer

1-1/2	.110/.374	3	\$140.	8	\$180.	3/4 Shank 3.5 OAL
1-1/2	.375/.505	3	\$175.	8	\$215.	
1-3/4	.120/.374	4	\$165.	10	\$210.	
1-3/4	.375/.505	4	\$190.	10	\$235.	
2	.120/.374	4	\$195.	12	\$250.	
2	.375/.505	4	\$235.	12	\$285.	
2-1/4	.120/.374	4	\$215.	12	\$285.	
2-1/4	.375/.505	4	\$250.	12	\$315.	
2-1/2	.120/.374	6	\$235.	12	\$310.	
2-1/2	.375/.505	6	\$275.	12	\$355.	

Suggested Starting Data:
Ferrous 150-250 SFM; .001/.003 IPT
Non-Ferrous 1K-3K SFM; .002/.006 IPT

Phone 916 408-2442 FAX 916 408-0740

Toll free phone 866 440-8665



A. B. TOOLS, INC.
1051 Aviation Blvd.
Lincoln, CA, 95648-9312

If any product is not satisfactory
we will modify, replace or refund.

www.abtoolsinc.com
E-Mail: mail@abtoolsinc.com

Extra Long Carbide Tipped Keyseat Cutters with your decimal width in 4-6 working days

Machining what part material, please? _____

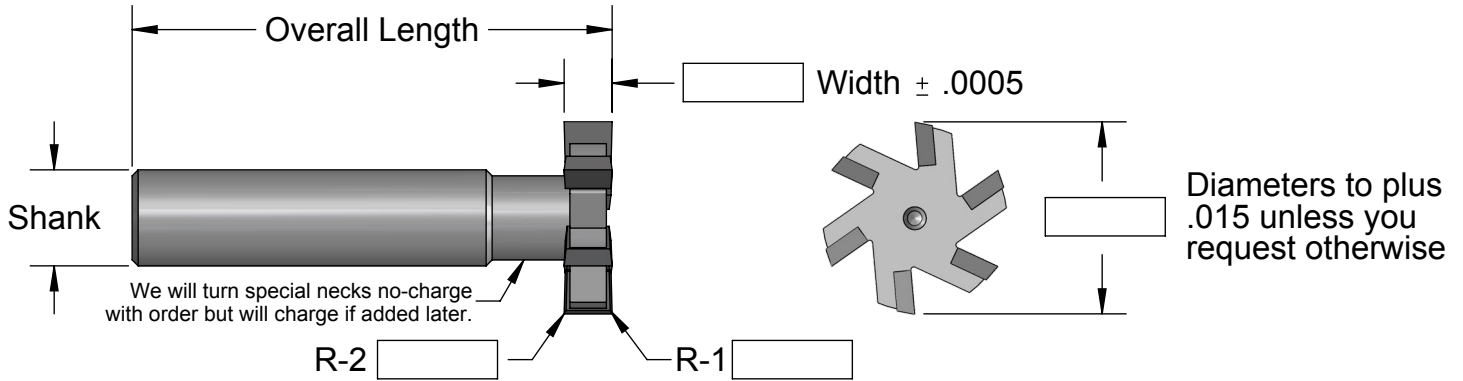

Diameter Plus .015 Minus Zero	Width Range	Basic Cutter Prices				Shank & Overall Length
		For Aluminum		For Ferrous		
		Flutes	Price	Flutes	Price	
5/8	.065/.190	2	\$145.	5	\$160.	1/2 Shank 4.5 OAL
3/4	.065/.220	2	\$145.	5	\$160.	
7/8	.075/.255	2	\$155.	6	\$165.	
1	.085/.315	2	\$160.	6	\$175.	
1-1/8	.110/.315	2	\$160.	6	\$190.	
1-1/4	.110/.350	3	\$165.	8	\$200.	
1-3/8	.110/.380	3	\$175.	8	\$210.	

For Minor Modifications add to your basic price.

1 CHAMFER \$35.
2 CHAMFERS \$50.

1 RADIUS \$40.
2 RADII \$60.
FULL RADIUS \$60.

1-1/2	.110/.374	3	\$195.	8	\$235.	3/4 Shank 6.0 OAL
1-1/2	.375/.505	3	\$230.	8	\$275.	
1-3/4	.120/.374	4	\$215.	10	\$270.	
1-3/4	.375/.505	4	\$250.	10	\$300.	
2	.120/.374	4	\$260.	12	\$310.	
2	.375/.505	4	\$290.	12	\$360.	
2-1/4	.120/.374	4	\$280.	12	\$360.	
2-1/4	.375/.505	4	\$320.	12	\$415.	
2-1/2	.120/.374	6	\$310.	12	\$400.	
2-1/2	.375/.505	6	\$325.	12	\$435.	

Staggered tooth Cutters add 30% to basic price
(2) piece minimum

Slot plus topping chamfer

Suggested Starting Data:
Ferrous 150-250 SFM; .001/.003 IPT
Non-Ferrous 1K-3K SFM; .002/.006 IPT

Phone 916 408-2442 FAX 916 408-0740

Toll free phone 866 440-8665



A. B. TOOLS, INC.
1051 Aviation Blvd.
Lincoln, CA, 95648-9312

If any product is not satisfactory
we will modify, replace or refund.

www.abtoolsinc.com
E-Mail: mail@abtoolsinc.com

Solid Carbide Slotting (Keyseat) Cutters .625 diameter and smaller your decimal width in 4-6 working days

Machining what part material, please? _____

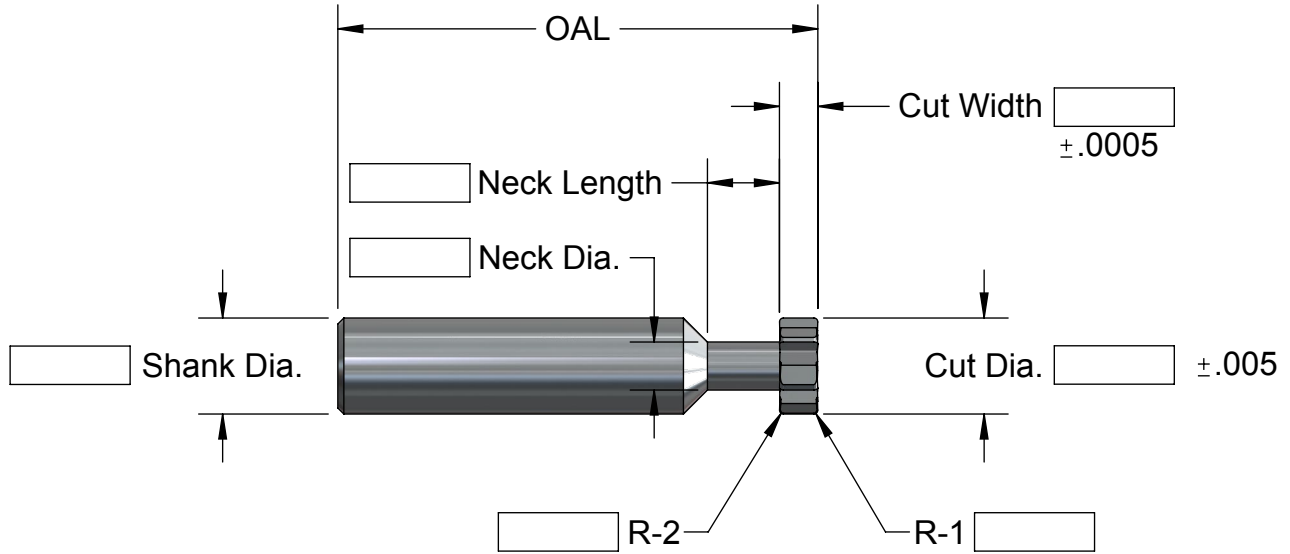

Suggested starting data:
 Ferrous 150 to 300 SFM; .001/.003 IPT
 Non-Ferrous 1K-3K SFM; .002/.006 IPT
 For thin or weak necked cutters, .0005 IPT

Number of flutes is your choice based on feasibility. We suggest coarse for non-ferrous, medium for titanium/stainless & maximum for cast iron and tough materials.

Cut Diameter	Shank & OAL	Basic Price
.030/.060	3/16 X 2	\$105.
.062/.186	3/16 X 2	\$90.
.188/.248	1/4 X 2	\$95.
.250/.390	3/8 X 2.5	\$105.
.400/.515	1/2 X 2.5	\$115.
.515/.625	5/8 X 3	\$135.

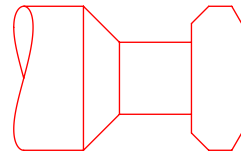

One Chamfer \$35.
Two Chamfers \$50.

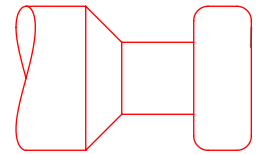

One Radius \$40.
Two Radii \$60.
Full Radius \$60.

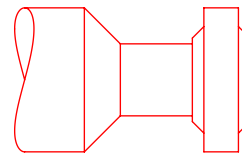

Slot plus top Chamfers
Upon Request

Add above prices to the basic price for minor modifications.



Phone 916 408-2442 FAX 916 408-0740
 A. B. TOOLS, INC.
 1051 Aviation Blvd.
 Lincoln, CA, 95648-9312

If any product is not satisfactory
we will modify, replace or refund.

Toll free phone 866 440-8665
 www.abtoolsinc.com
 E-Mail: mail@abtoolsinc.com

Solid Carbide Slotting (Keyseat) Cutters from .530 to 2.0 diameters

your decimal width in 4-6 working days

Machining what part material, please? _____

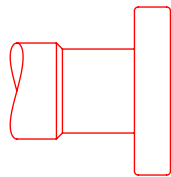
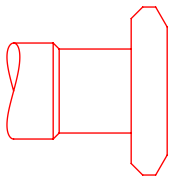
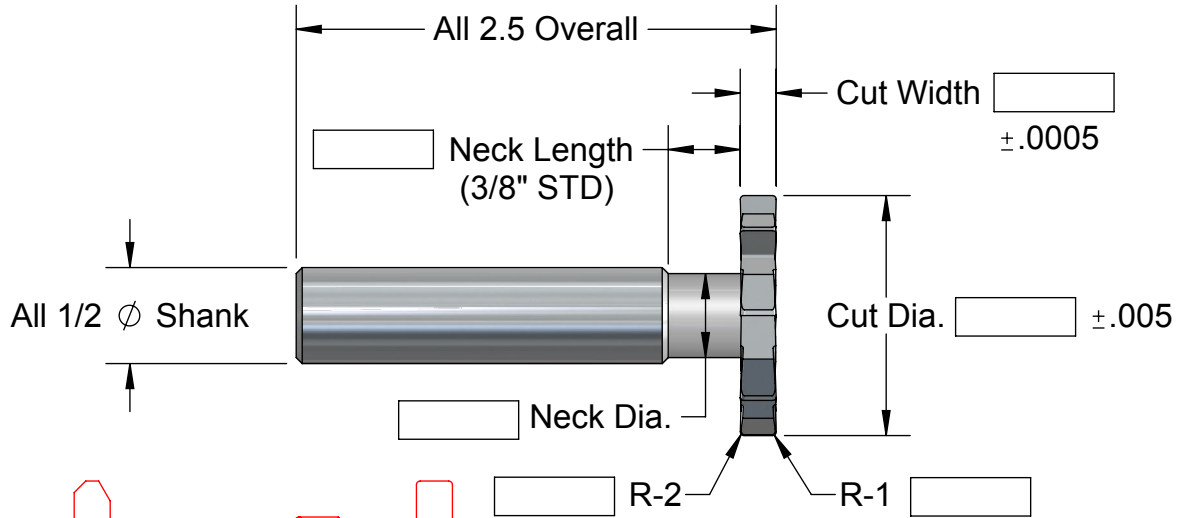

Necks can be modified at no extra charge if feasible.

One Chamfer \$35.
Two Chamfers \$50.

One Radius \$40.
Two Radii \$60.
Full Radius \$60.

Suggested starting data:
Ferrous 150 to 300 SFM; .001/.003 IPT
Non-Ferrous 1K-3K SFM; .002/.006 IPT
For thin or weak necked cutters, .0005 IPT

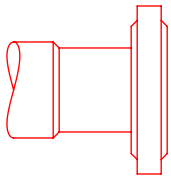

Slot plus top Chamfers
Upon Request

Number of flutes is your choice based on feasibility. We suggest coarse for non-ferrous, medium for titanium/stainless & maximum for cast iron and tough materials.

Cut Dia.	Max. no. of Flutes	As-Cast Neck Dia.	Basic Prices for .010 thru .135 Widths	Basic Prices for .136 thru .260 Widths	Basic Prices for .261 thru .374 Widths	Basic Prices for .375 thru .440 Widths
.625	8	3/8	\$160.	\$165.	\$170.	
.750	10	7/16	\$165.	\$170.	\$175.	
1.00	12	7/16	\$170.	\$180.	\$185.	
1.25	14	7/16	\$180.	\$190.	\$210.	\$265.
1.50	16	7/16	\$195.	\$215.	\$250.	\$285.
1.75	18	15/32	\$220.	\$240.	\$275.	\$325.
2.00	20	15/32	\$250.	\$265.	\$295.	\$345.

Phone 916 408-2442 FAX 916 408-0740

Toll free phone 866 440-8665



A. B. TOOLS, INC.
1051 Aviation Blvd.
Lincoln, CA, 95648-9312

If any product is not satisfactory we will modify, replace or refund.

www.abtoolsinc.com
E-Mail: mail@abtoolsinc.com

Standard Keyway Cutters Solid Carbide

**Specials in 4-6
Working Days**

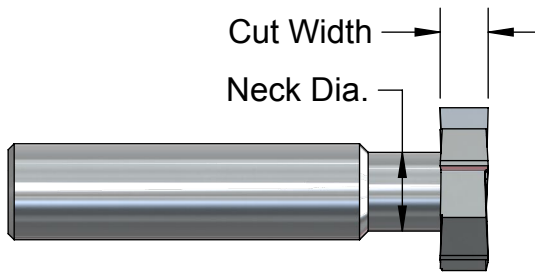

**Straight Tooth
Shown Full Size
(#807 Keyway Cutter)**

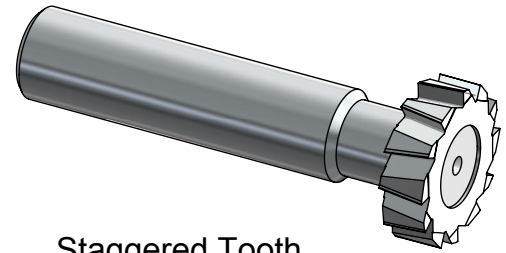
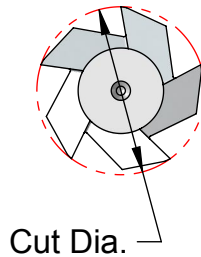

**Staggered Tooth
Shown Full Size
(#807 Keyway Cutter)**

Ind. Std. #	Cut Dia.	Cut Width	Neck Dia.	Neck Length	No. of Flutes Aluminum	No. of Flutes Steel	No. of Flutes Staggered	Price	
								Straight Tooth	Staggered Tooth
202	1/4	1/16	.064	.090	3	6	6	\$85.	\$100.
202.5	5/16	1/16	.065	.090	3	6	6	\$85.	\$100.
302.5	5/16	3/32	.096	.150	3	6	6	\$85.	\$100.
203	3/8	1/16	.209	.125	3	6	6	\$95.	\$110.
303	3/8	3/32	.146	.180	3	6	6	\$95.	\$110.
403	3/8	1/8	.090	.180	3	6	6	\$95.	\$110.
204	1/2	1/16	.140	.090	3	8	8	\$105.	\$120.
304	1/2	3/32	.160	.180	3	8	8	\$105.	\$120.
404	1/2	1/8	.190	.250	3	8	8	\$105.	\$120.
305	5/8	3/32	.190	.150	4	8	8	\$160.	\$176.
405	5/8	1/8	.220	.250	4	8	8	\$160.	\$176.
505	5/8	5/32	.250	.250	4	8	8	\$160.	\$176.
605	5/8	3/16	.280	.280	4	8	8	\$160.	\$176.
406	3/4	1/8	.220	.250	4	10	10	\$165.	\$182.
506	3/4	5/32	.250	.250	4	10	10	\$165.	\$182.
606	3/4	3/16	.280	.280	4	10	10	\$165.	\$182.
806	3/4	1/4	.340	.250	4	10	10	\$165.	\$182.
507	7/8	3/16	.250	.280	5	12	12	\$170.	\$187.
707	7/8	7/32	.310	.250	5	12	12	\$170.	\$187.
807	7/8	1/4	.340	.250	5	12	12	\$170.	\$187.

Phone 916 408-2442 FAX 916 408-0740

Toll free phone 866 440-8665



A. B. TOOLS, INC.
1051 Aviation Blvd.
Lincoln, CA, 95648-9312

If any product is not satisfactory
we will modify, replace or refund.

www.abtoolsinc.com
E-Mail: mail@abtoolsinc.com

Standard Keyway Cutters Carbide Tipped

**Specials in 4-6
Working Days**

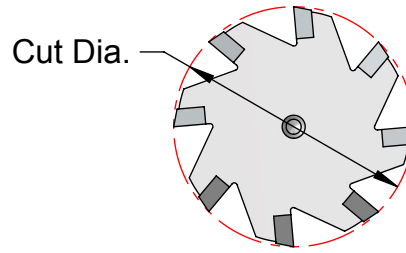
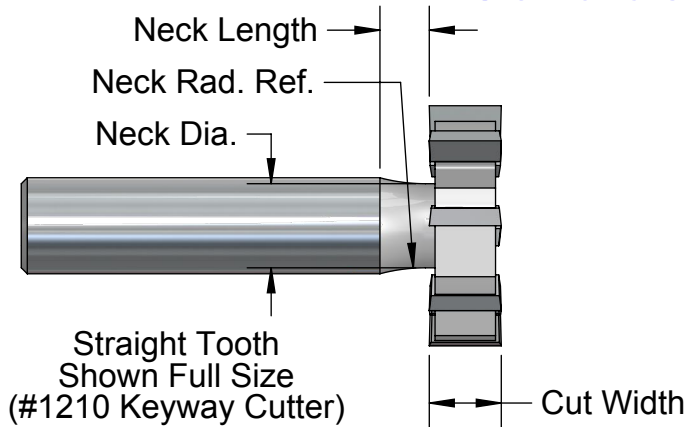

All shanks are 1/2" Dia. and 2-1/2" overall

Ind. Std. #	Cut Dia.	Cut Width	Neck Dia.	Neck Length	Neck Rad. Ref.	No. of Flts.	Price	
							Straight Tooth	Staggered Tooth
608	1	3/16	.280	.440	.85	6	\$115.	\$150.
708	1	7/32	.310	.415	.865			
808	1	1/4	.340	.385	.880			
1008	1	5/16	.375	.219	N/A			
1208	1	3/8	.410	.219	N/A			
609	1-1/8	3/16	.310	.410	.855	6	\$130.	\$165.
709	1-1/8	7/32	.340	.380	.875			
809	1-1/8	1/4	.380	.346	.895			
1009	1-1/8	5/16	.435	.250	N/A			
610	1-1/4	3/16	.310	.410	.855	8	\$145.	\$185.
710	1-1/4	7/32	.340	.380	.875			
810	1-1/4	1/4	.375	.350	.895			
1010	1-1/4	5/16	.485	.250	N/A			
1210	1-1/4	3/8	.485	.250	N/A			
811	1-3/8	1/4	.400	.310	.930	8	\$150.	\$190.
1011	1-3/8	5/16	.485	.313	N/A			
1211	1-3/8	3/8	.485	.313	N/A			
812	1-1/2	1/4	.430	.310	N/A	8	\$170.	\$210.
1012	1-1/2	5/16	.490	.250	N/A			
1212	1-1/2	3/8	.490	.250	N/A			

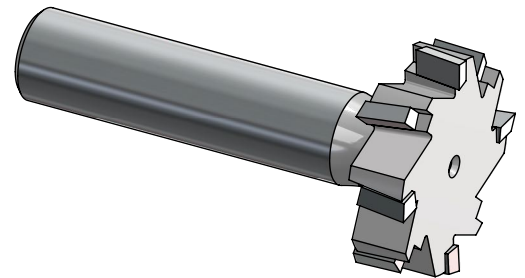

Staggered Tooth Shown Full Size (#1210 Keyway Cutter)

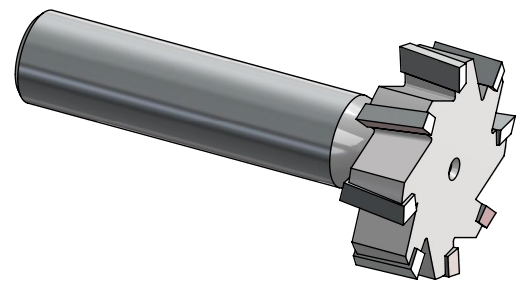

Staggered Tooth All Ends Cut Shown Full Size (#1210 Keyway Cutter)

Phone 916 408-2442 FAX 916 408-0740

A. B. TOOLS, INC.
1051 Aviation Blvd.
Lincoln, CA, 95648-9312

If any product is not satisfactory we will modify, replace or refund.

Toll free phone 866 440-8665

www.abtoolsinc.com
E-Mail: mail@abtoolsinc.com



Solid Carbide Picatinny Rail Cutters

Specials in 4-6 Working Days

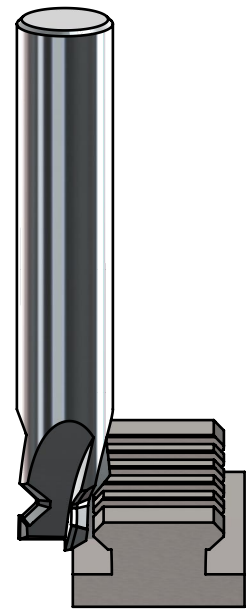
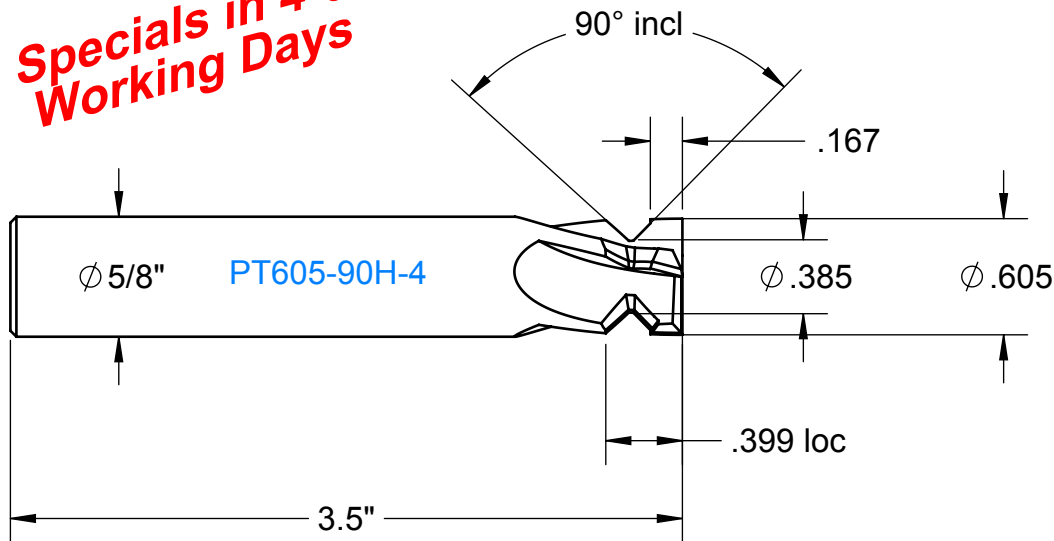

Number	No. of flutes	Prices
PT605-90H	3	\$135.
PT605-90H-4	4	\$142.50
PT480-90H	2	\$125.
PT480-90H-3	3	\$132.50

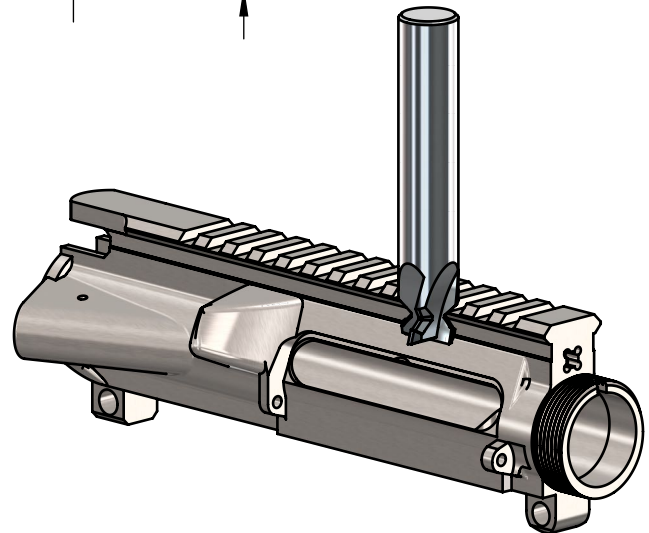
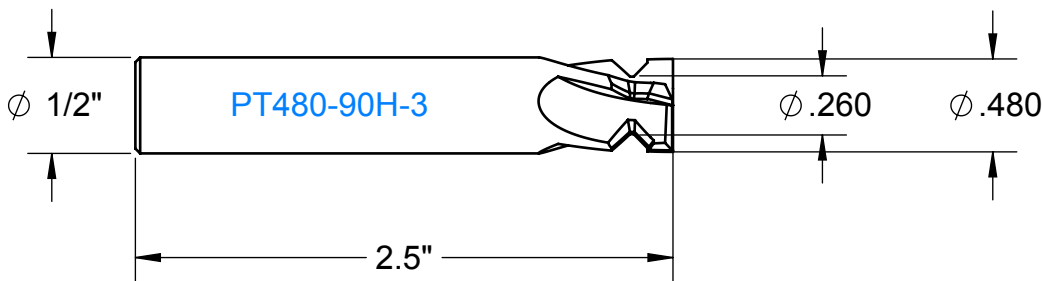

Military Specs

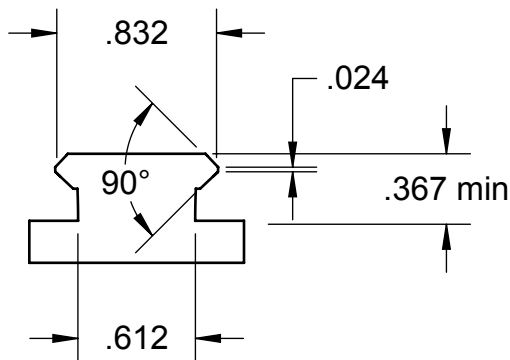

Phone 916 408-2442 FAX 916 408-0740

A. B. TOOLS, INC.
1051 Aviation Blvd.
Lincoln, CA, 95648-9312

If any product is not satisfactory
we will modify, replace or refund.

Toll free phone 866 440-8665

www.abtoolsinc.com
E-Mail: mail@abtoolsinc.com



Solid Carbide Male Picatinny (Fixture) Cutter

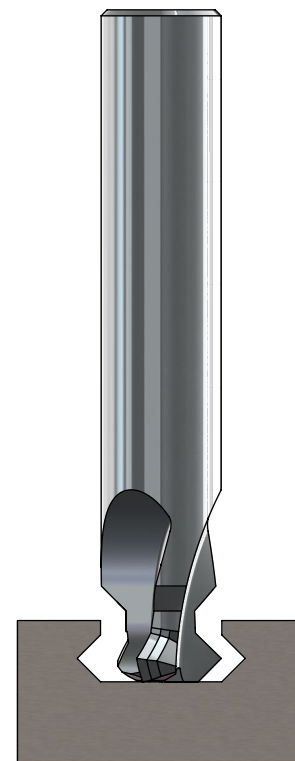
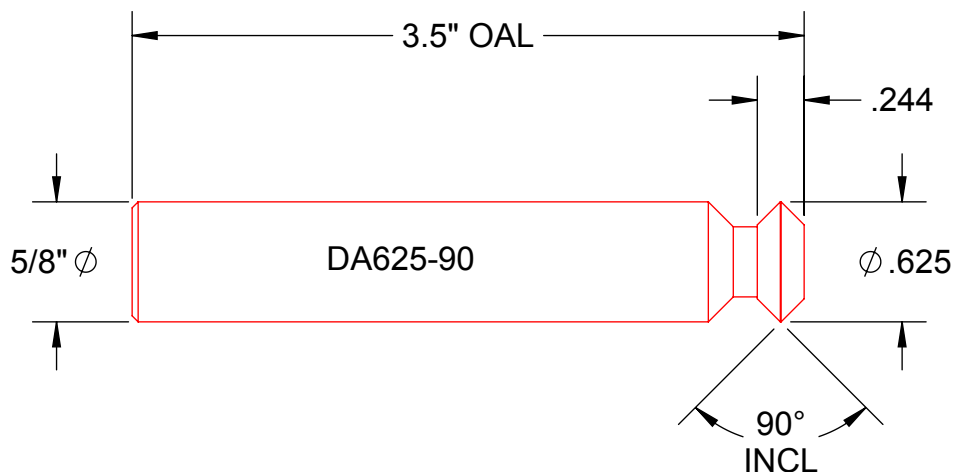

Number	Flutes	Price	
		No-Coat	AlTiN
DA625-90	3	\$165.	\$177.
DA625-90	4	\$172.50	\$184.50

Special Male Picatinny (Fixture) Cutters in 4-6 Working Days

Machining what part material, please? _____

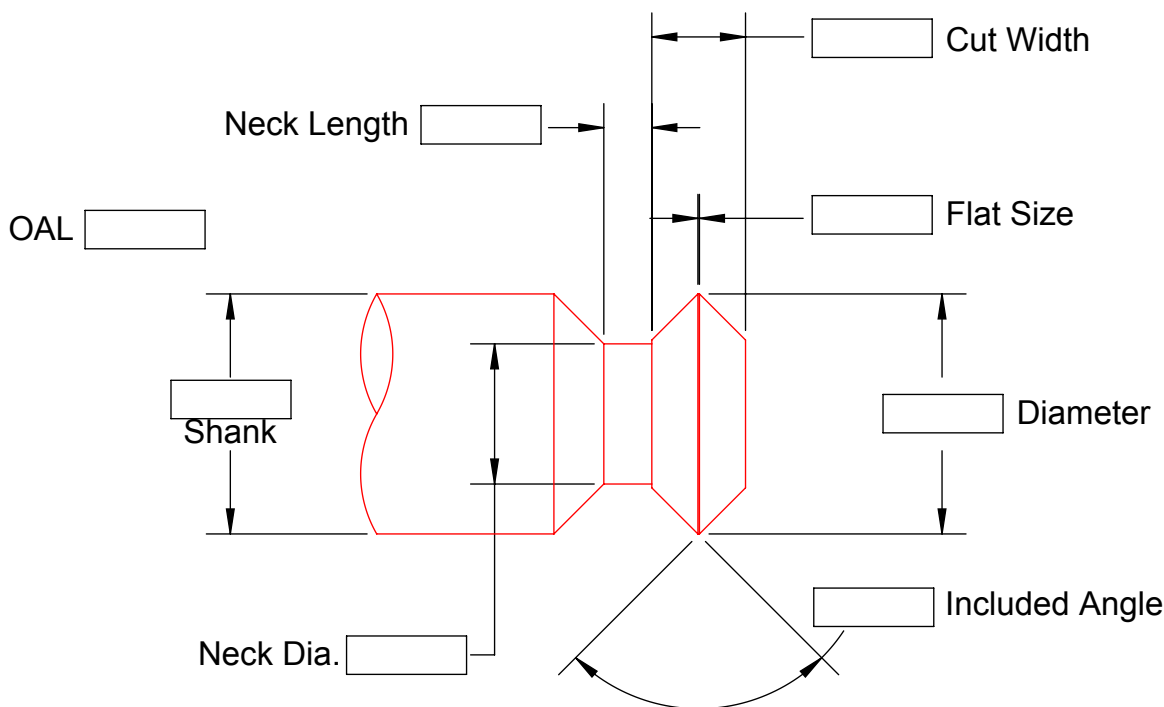

Phone 916 408-2442 FAX 916 408-0740

Toll free phone 866 440-8665



A. B. TOOLS, INC.
1051 Aviation Blvd.
Lincoln, CA, 95648-9312

If any product is not satisfactory
we will modify, replace or refund.

www.abtoolsinc.com
E-Mail: mail@abtoolsinc.com

Solid Carbide Slot & Chamfer Picatinny Rail End Mill

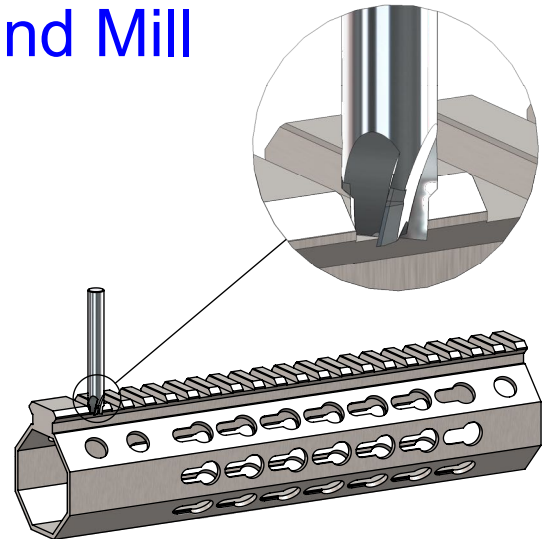
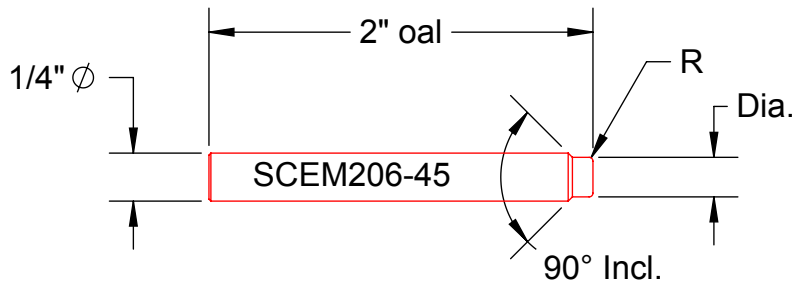

Number	Dia.	Radius	Price			AITiN add
			3 flutes	4 flutes	5 flutes	
SCEM206-45	.206	None	\$55.	\$65.	\$76.	\$4.
SCEM206-45-10R	.206	.010	\$65.	\$76.	\$86.	\$4.
SCEM206-45-20R	.206	.020	\$65.	\$76.	\$86.	\$4.
SCEM210-45	.210	None	\$55.	\$65.	\$76.	\$4.
SCEM210-45-10R	.210	.010	\$65.	\$76.	\$86.	\$4.
SCEM210-45-20R	.210	.020	\$65.	\$76.	\$86.	\$4.

Special Slot & Chamfer End Mills in 4-6 Working Days

Machining what part material, please? _____

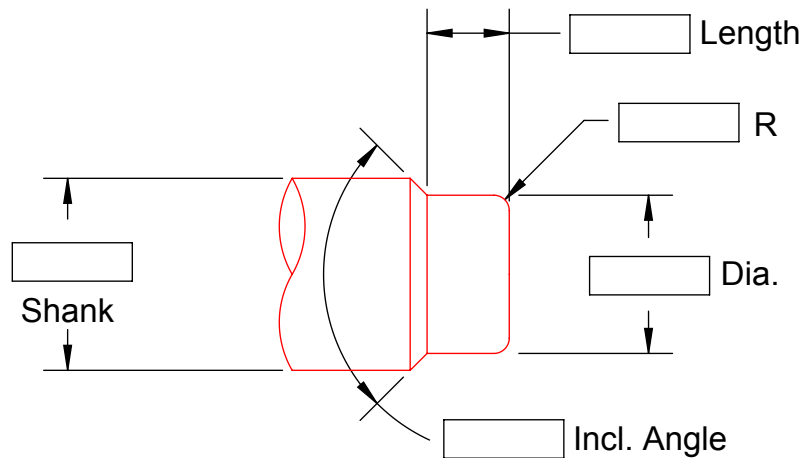

Phone 916 408-2442 FAX 916 408-0740

Toll free phone 866 440-8665

A. B. TOOLS, INC.
1051 Aviation Blvd.
Lincoln, CA, 95648-9312

If any product is not satisfactory
we will modify, replace or refund.

www.abtoolsinc.com
E-Mail: mail@abtoolsinc.com



Solid Carbide Keymod Cutter

(3) flutes

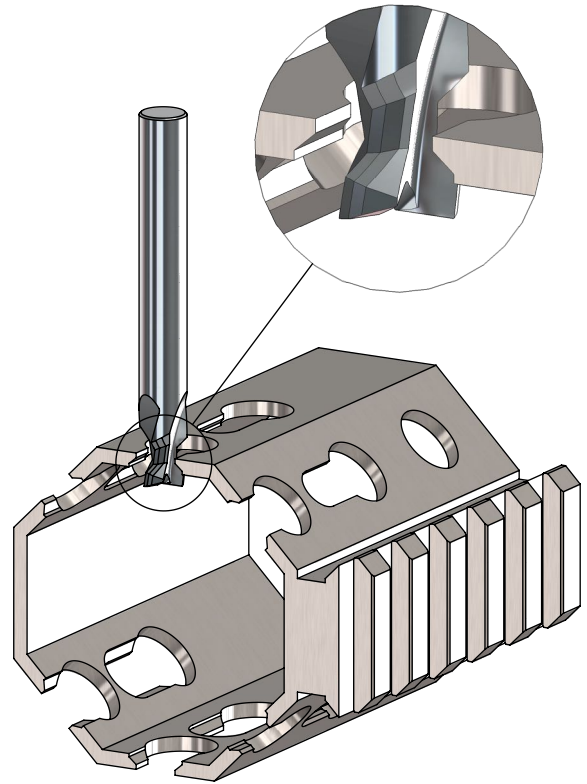
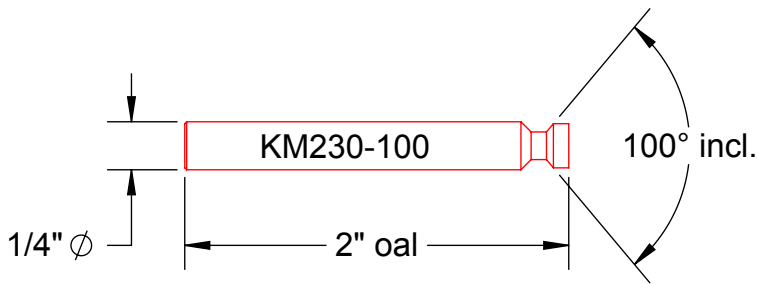

Number	Price	
	No-Coat	AlTiN
KM230-100	\$90.	\$94.

Special Keymod Cutters in 4-6 Working Days

Machining what part material, please? _____

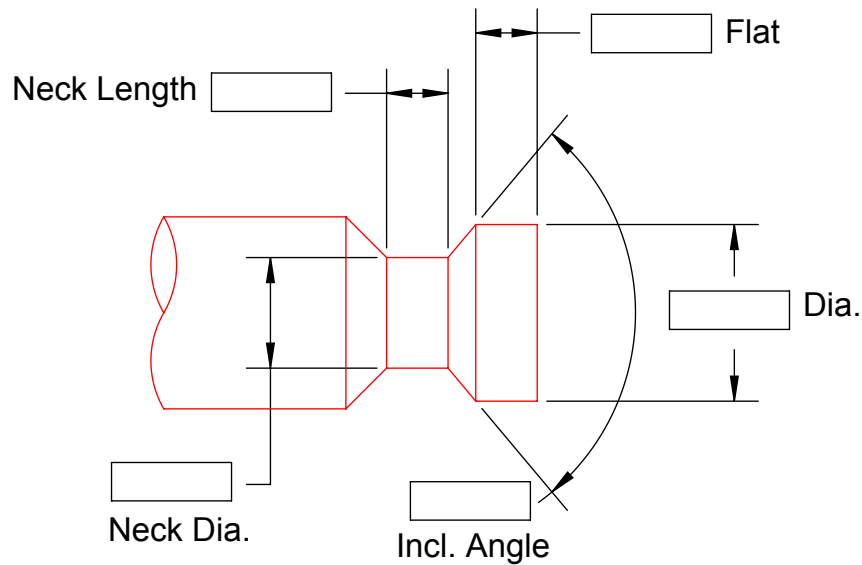

Phone 916 408-2442 FAX 916 408-0740

Toll free phone 866 440-8665

A. B. TOOLS, INC.
1051 Aviation Blvd.
Lincoln, CA, 95648-9312

If any product is not satisfactory
we will modify, replace or refund.

www.abtoolsinc.com
E-Mail: mail@abtoolsinc.com



Charging Handle Slot Cutter

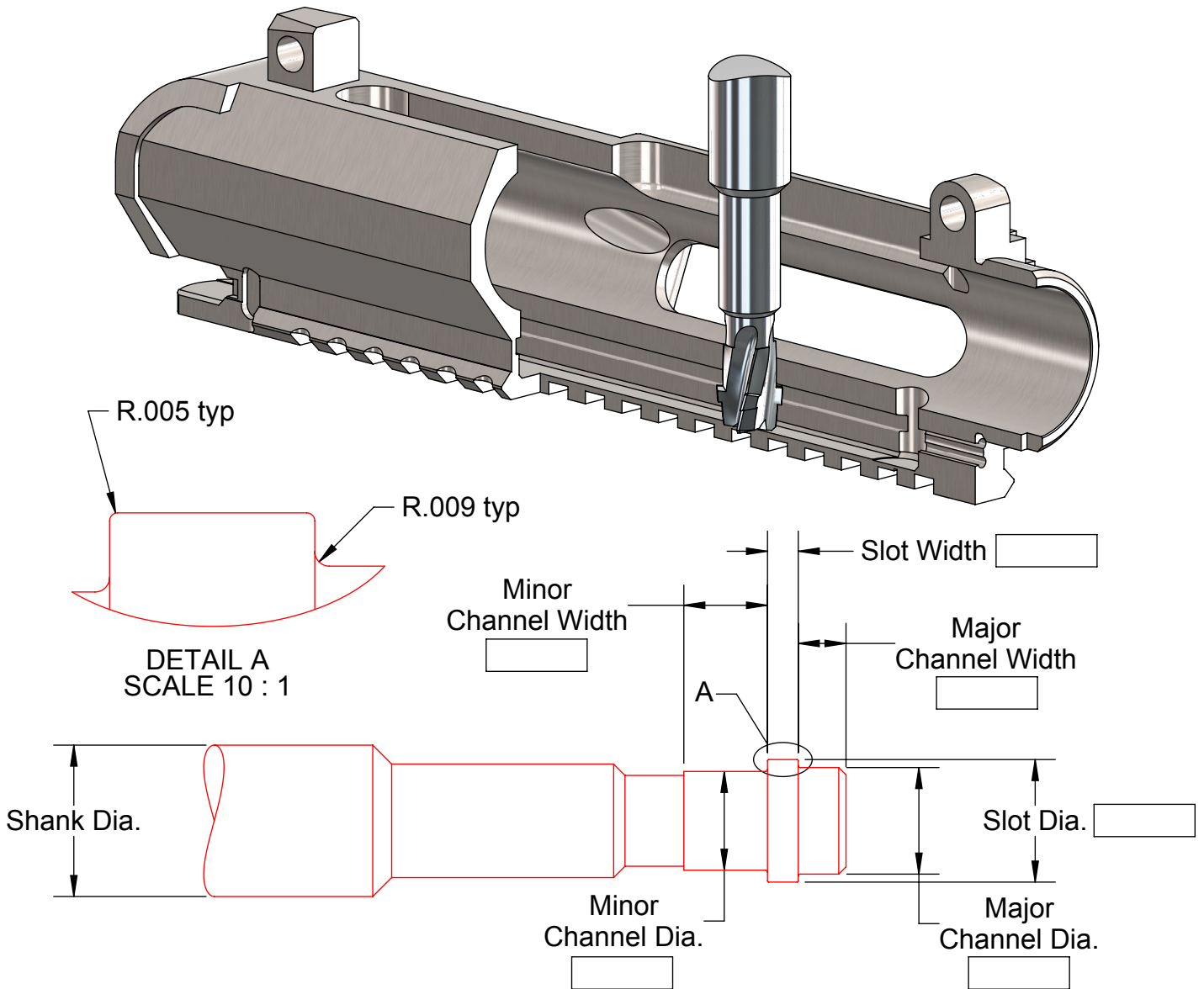

Special Charging Handle Slot Cutters in 4-6 working days

Machining what part material, please? _____

Number	Slot Dia.	Slot Width	Helix	Shank Dia. & OAL	No. of Flutes	Price	
						No-Coat	AlTiN
CHSC-R15	.486	.127	15°	5/8 X 5	3	\$225.	\$240.
CHSC-R30	.486	.127	30°	5/8 X 5	3	\$225.	\$240.
CHSC-F15	.506	.127	15°	5/8 X 5	4	\$225.	\$240.
CHSC-F30	.506	.127	30°	5/8 X 5	4	\$225.	\$240.

Phone 916 408-2442 FAX 916 408-0740

Toll free phone 866 440-8665



A. B. TOOLS, INC.
1051 Aviation Blvd.
Lincoln, CA, 95648-9312

If any product is not satisfactory
we will modify, replace or refund.

www.abtoolsinc.com
E-Mail: mail@abtoolsinc.com

Solid Carbide Dovetail Cutters for O-Ring Grooves

NUMBER	O-RING SIZE	NECK Ø TSC	NECK Ø OVER R	SLOT DEPTH	TOP RAD.	BOTTOM RAD.	MAJOR Ø	PRICE	AITIN
DT1/16 DT1/16-5	.070	.057 .052	.0624 .0574	.051	.005	.015	.0862 .0812	\$68.	\$72.
DT1/16-054	.070	.059	.064	.054	.005	.016	.090	\$68.	\$72.
DT3/32 DT3/32-8	.103	.085 .077	.0958 .0878	.082	.010	.015	.1418 .1338	\$68.	\$72.
DT1/8 DT1/8-10	.139	.115 .105	.1258 .1158	.112	.010	.031	.1812 .1712	\$75.	\$79.
DT3/16 DT3/16-12	.210	.173 .161	.1892 .1772	.172	.015	.031	.2927 .2807	\$85.	\$90.
DT1/4 DT1/4-15	.275	.233 .218	.2492 .2342	.232	.015	.062	.3726 .3576	\$95.	\$101.
DT3/8 DT3/8-15	.375	.317 .302	.3386 .3236	.317	.020	.094	.4978 .4828	\$122.	\$130.

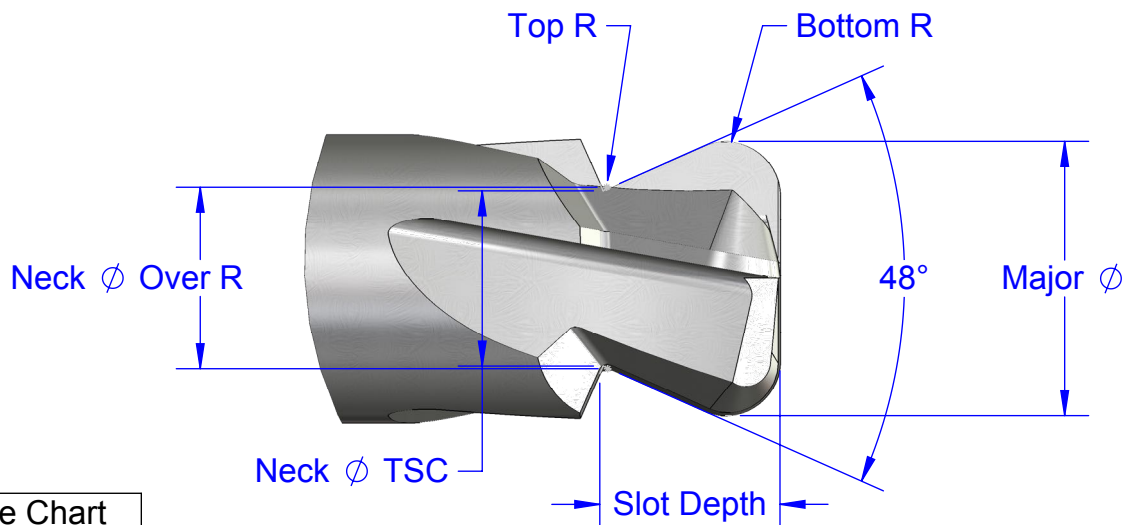

Reference Chart

NUMBER	NO. OF FLUTES	SHANK Ø	OAL
DT1/16 DT1/16-5	1	3/16	2
DT1/16-054	2	3/16	2
DT3/32 DT3/32-8	2	3/16	2
DT1/8 DT1/8-10	2	1/4	2
DT3/16 DT3/16-12	3	5/16	2.5
DT1/4 DT1/4-15	3	3/8	2.5
DT3/8 DT3/8-15	4	1/2	2.5

**Specials in 4-6
Working Days
(See Page 18)**

Phone 916 408-2442 FAX 916 408-0740

Toll free phone 866 440-8665



A. B. TOOLS, INC.
1051 Aviation Blvd.
Lincoln, CA, 95648-9312

If any product is not satisfactory
we will modify, replace or refund.

www.abtoolsinc.com
E-Mail: mail@abtoolsinc.com

Solid Carbide Dovetail for O-Ring Grooves (Metric)

NUMBER	O-RING SIZE	NECK Ø TSC	NECK Ø OVER R	SLOT DEPTH	TOP RAD.	BOTTOM RAD.	MAJOR Ø	PRICE	AITiN
DT3MM	3MM	.096	.102	.094	.010	.016	.162	\$68.	\$72.
DT3.5MM	3.5MM	.110	.121	.110	.010	.031	.1745	\$68.	\$72.
DT4MM	4MM	.122	.133	.126	.010	.031	.201	\$72.	\$76.
DT4.5MM	4.5MM	.138	.149	.144	.010	.031	.232	\$72.	\$76.
DT5MM	5MM	.152	.162	.163	.010	.031	.264	\$85.	\$90.
DT5.5MM	5.5MM	.165	.183	.181	.016	.031	.293	\$85.	\$90.
DT6MM	6MM	.179	.196	.199	.016	.031	.323	\$95.	\$101.
DT6.5MM	6.5MM	.193	.210	.2165	.016	.031	.352	\$95.	\$101.
DT7MM	7MM	.207	.224	.234	.016	.059	.352	\$95.	\$101.
DT7.5MM	7.5MM	.2205	.238	.252	.016	.059	.381	\$122.	\$130.
DT8MM	8MM	.236	.258	.270	.020	.059	.413	\$122.	\$130.
DT8.5MM	8.5MM	.250	.272	.289	.020	.059	.444	\$122.	\$130.
DT9MM	9MM	.264	.285	.307	.020	.059	.473	\$122.	\$130.
DT9.5MM	9.5MM	.278	.299	.323	.020	.059	.501	\$122.	\$130.
DT10MM	10MM	.291	.313	.3425	.020	.059	.533	\$155.	\$165.

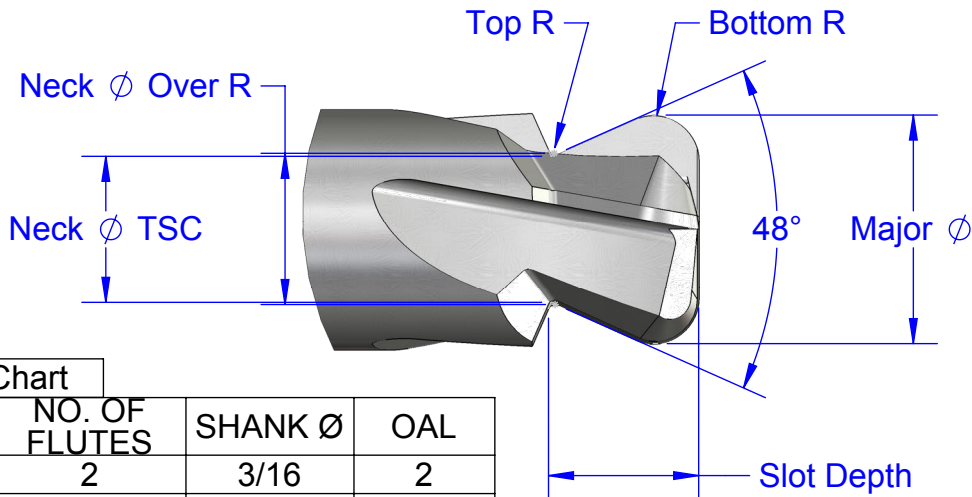

Reference Chart			
NUMBER	NO. OF FLUTES	SHANK Ø	OAL
DT3MM	2	3/16	2
DT3.5MM	2	3/16	2
DT4MM	2	1/4	2
DT4.5MM	2	1/4	2
DT5MM	3	5/16	2.5
DT5.5MM	3	5/16	2.5
DT6MM	3	3/8	2.5
DT6.5MM	3	3/8	2.5
DT7MM	3	3/8	2.5
DT7.5MM	3	1/2	2.5
DT8MM	3	1/2	2.5
DT8.5MM	3	1/2	2.5
DT9MM	3	1/2	2.5
DT9.5MM	3	1/2	2.5
DT10MM	3	5/8	3.5

**Specials in 4-6
Working Days
(See Page 18)**



Phone 916 408-2442 FAX 916 408-0740

A. B. TOOLS, INC.
1051 Aviation Blvd.
Lincoln, CA, 95648-9312

If any product is not satisfactory
we will modify, replace or refund.

Toll free phone 866 440-8665

www.abtoolsinc.com
E-Mail: mail@abtoolsinc.com

Solid Carbide Dovetail Cutters for O-Ring Grooves WITHOUT Drop Hole Provision

NUMBER	O-RING SIZE	PART Ø TSC	NECK Ø OVER R	SLOT DEPTH	TOP RAD.	BOTTOM RAD.	NO. OF FLUTES	PRICE	AITiN
DTNDH1/16	.070	.057	.036	.051	.005	.015	1	\$68.	\$72.
DTNDH3/32	.103	.085	.048	.082	.010	.015	1	\$68.	\$72.
DTNDH1/8	.139	.115	.0685	.112	.010	.031	2	\$75.	\$79.
DTNDH3/16	.210	.173	.0835	.172	.015	.031	2	\$85.	\$90.
DTNDH1/4	.275	.233	.1235	.232	.015	.062	2	\$95.	\$101.
DTNDH3/8	.375	.317	.178	.317	.020	.094	3	\$122.	\$130.

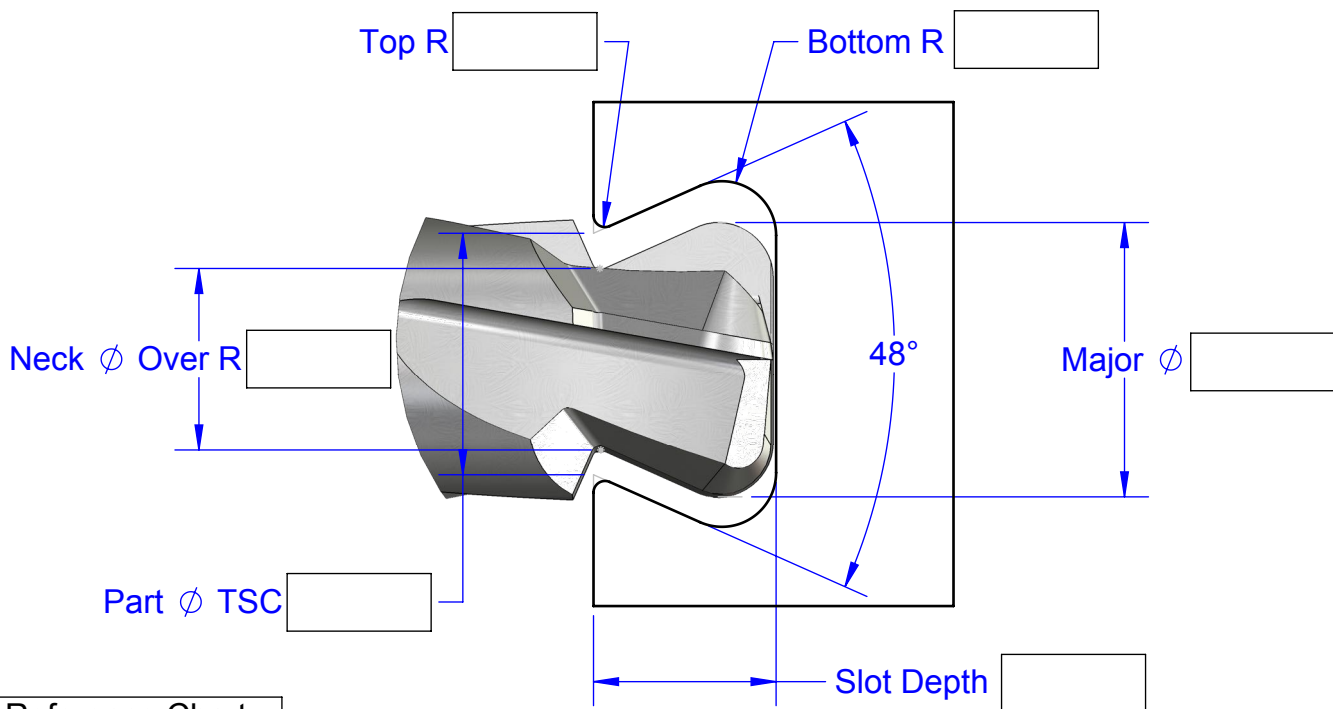

Reference Chart

NUMBER	MAJOR Ø	SHANK Ø	OAL
DTNDH1/16	.060	3/16	2
DTNDH3/32	.094	3/16	2
DTNDH1/8	.124	3/16	2
DTNDH3/16	.187	1/4	2
DTNDH1/4	.247	5/16	2.5
DTNDH3/8	.337	3/8	2.5

**Specials in 4-6
Working Days**



Phone 916 408-2442 FAX 916 408-0740

A. B. TOOLS, INC.
1051 Aviation Blvd.
Lincoln, CA, 95648-9312

If any product is not satisfactory
we will modify, replace or refund.

Toll free phone 866 440-8665

www.abtoolsinc.com
E-Mail: mail@abtoolsinc.com

Solid Carbide Dovetail Cutters for Half Dovetail O-Ring Grooves

NUMBER	O-RING SIZE	PART Ø TSC	NECK Ø OVER R	SLOT DEPTH	TOP RAD.	BOTTOM RAD.	NO. OF FLUTES	PRICE	AITiN
HDG1/16	.070	.065	.0545	.054	.005	.015	2	\$68.	\$72.
HDG3/32	.103	.096	.0775	.084	.010	.015	2	\$68.	\$72.
HDG1/8	.139	.126	.103	.114	.010	.031	2	\$75.	\$79.
HDG3/16	.210	.1915	.146	.1745	.015	.031	2	\$85.	\$90.
HDG1/4	.275	.256	.2005	.236	.015	.062	3	\$95.	\$101.
HDG3/8	.375	.354	.283	.321	.020	.093	4	\$122.	\$130.

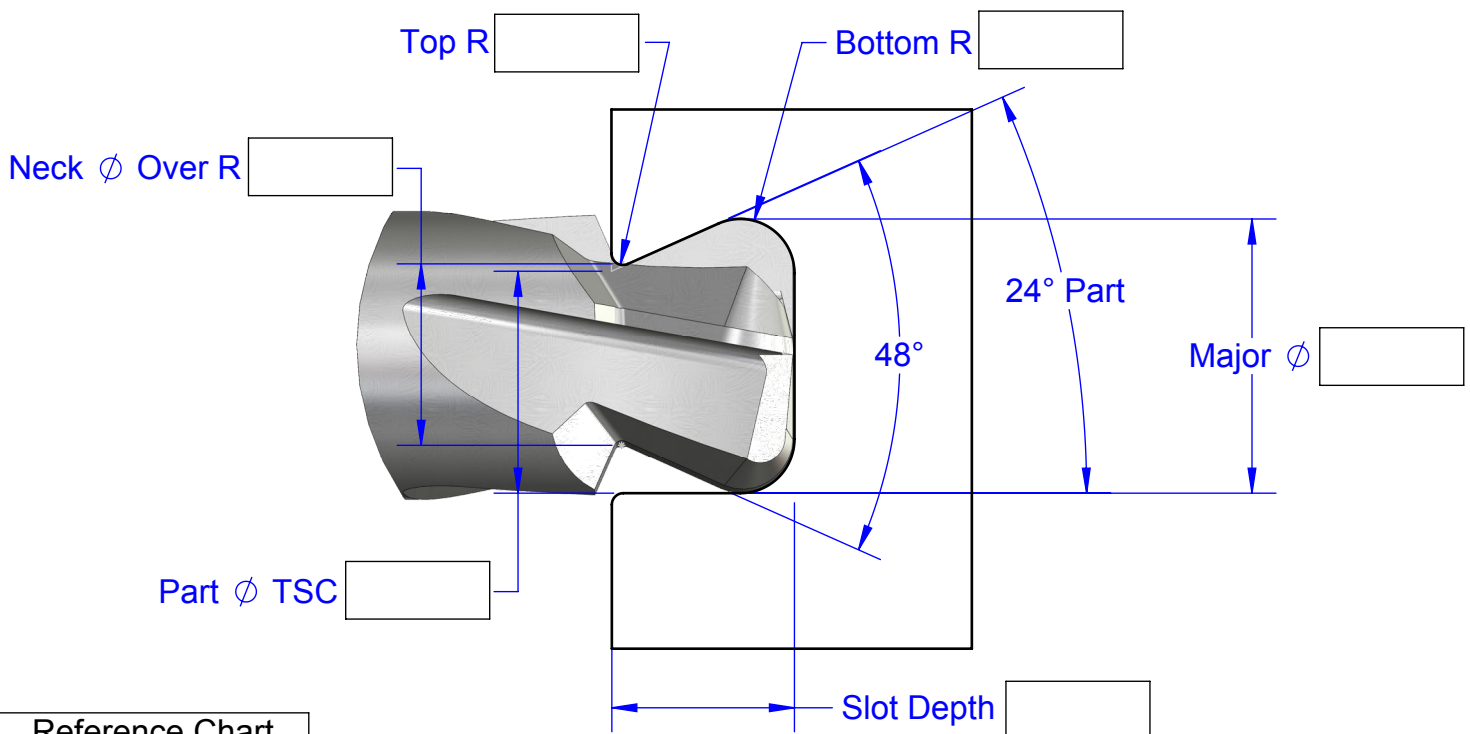

Reference Chart			
NUMBER	MAJOR Ø	SHANK Ø	OAL
HDG1/16	.081	3/16	2
HDG3/32	.125	3/16	2
HDG1/8	.160	3/16	2
HDG3/16	.253	5/16	2.5
HDG1/4	.328	3/8	2.5
HDG3/8	.447	1/2	2.5

Specials in 4-6
Working Days



Phone 916 408-2442 FAX 916 408-0740

A. B. TOOLS, INC.
1051 Aviation Blvd.
Lincoln, CA, 95648-9312

If any product is not satisfactory
we will modify, replace or refund.

Toll free phone 866 440-8665

www.abtoolsinc.com
E-Mail: mail@abtoolsinc.com

Solid Carbide O-Ring Dovetails for Lathes

Single flute carbide O-Ring form tools for lathe applications that match Parker-Hannifin standards

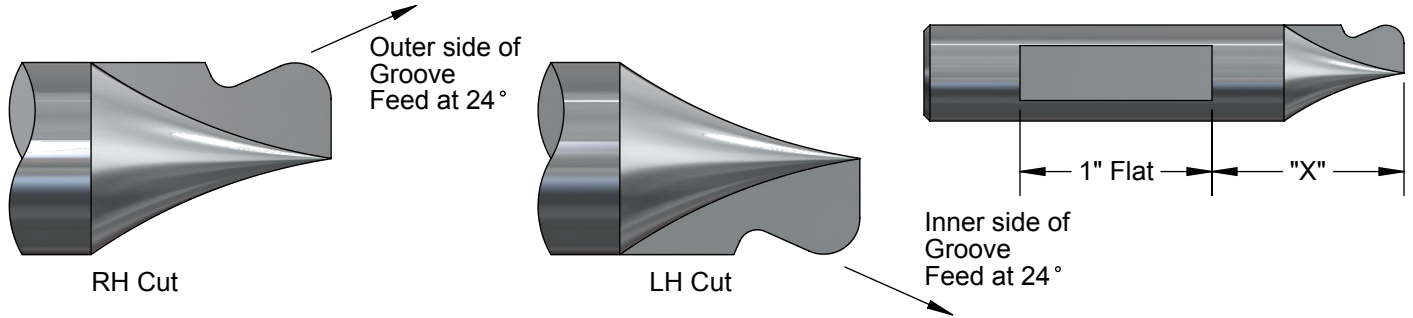

NUMBER		O'RING DIA.	*NECK DIA.	SLOT DEPTH	TOP RAD.	BOTT. RAD.	X	SHANK & OAL	PRICES	
RH Cut	LH Cut								No Coat	AlTiN
DTL1/16-R	DTL1/16-L	.070	.057	.051	.005	.015	1/2"	3/16 X 2	\$78.	\$81.
DTL1/16-054-R	DTL1/16-054-L	.070	.059	.054	.005	.016	1/2"	3/16 X 2	\$78.	\$81.
DTL3/32-R	DTL3/32-L	.103	.085	.082	.010	.015	1/2"	3/16 X 2	\$78.	\$81.
DTL1/8-R	DTL1/8-L	.139	.115	.112	.010	.031	5/8"	1/4 X 2	\$85.	\$89.
DTL3/16-R	DTL3/16-L	.210	.173	.172	.015	.031	3/4"	5/16 X 2.5	\$90.	\$97.
DTL1/4-R	DTL1/4-L	.275	.233	.232	.015	.062	7/8"	3/8 X 2.5	\$100.	\$107.
DTL3/8-R	DTL3/8-L	.375	.317	.317	.020	.094	1"	1/2 X 2.5	\$145.	\$154.

Specials in 4-6 working days

Machining what part material, please? _____

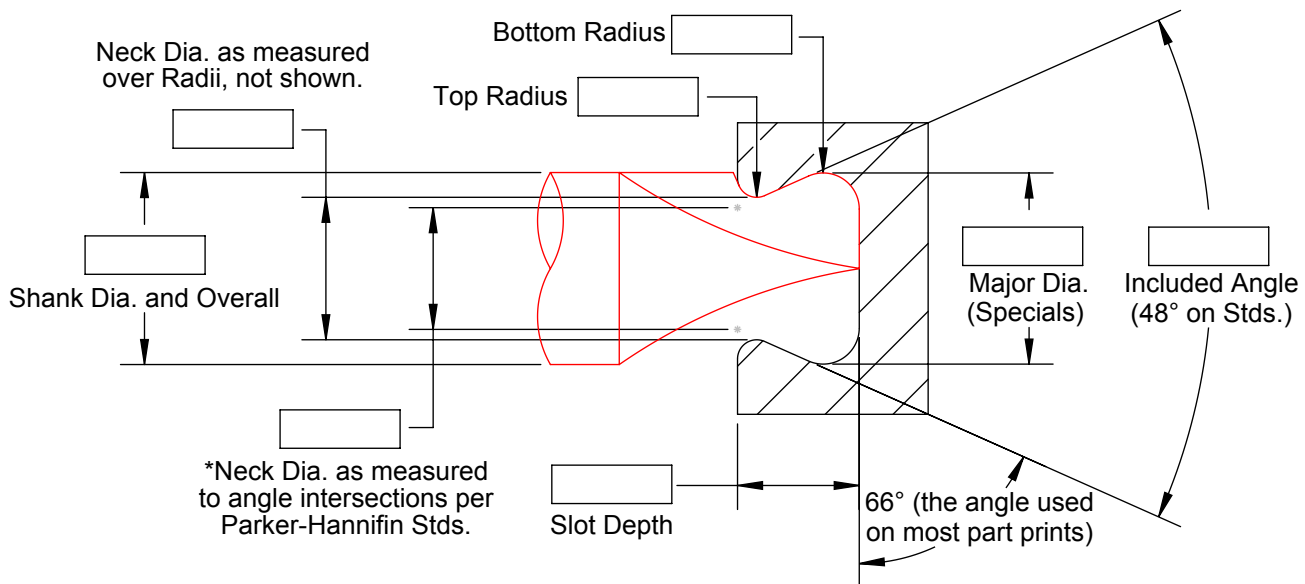

Special Carbide Cutters for O-Ring Grooves	To 1/4 Major Diameter	1 at \$175. and 2 at \$150. each
	.251 thru .375 Major Dia.	1 at \$210. and 2 at \$165. each
	.376 thru .500 Major Dia.	1 at \$250. and 2 at \$165. each

Phone 916 408-2442 FAX 916 408-0740

Toll free phone 866 440-8665



A. B. TOOLS, INC.
1051 Aviation Blvd.
Lincoln, CA, 95648-9312

If any product is not satisfactory we will modify, replace or refund.

www.abtoolsinc.com
E-Mail: mail@abtoolsinc.com

Solid Carbide Dovetail Cutters for O-Ring Grooves

Specials in 4-6 working days

Machining what part material, please? _____

Number of flutes is based on part material and Neck ϕ .

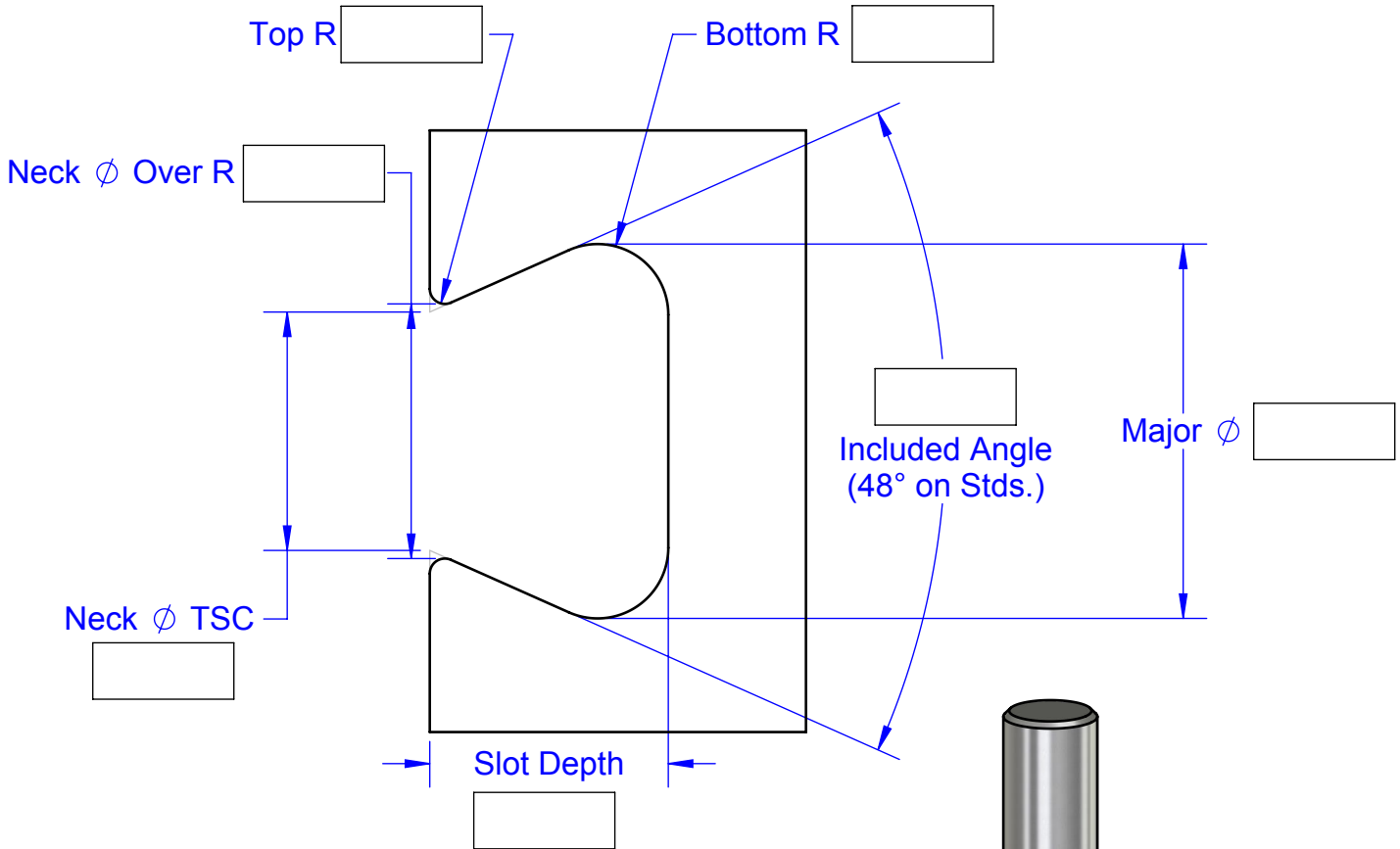

Shank ϕ and overall length are based on cutter Major ϕ . Or per request if feasible.

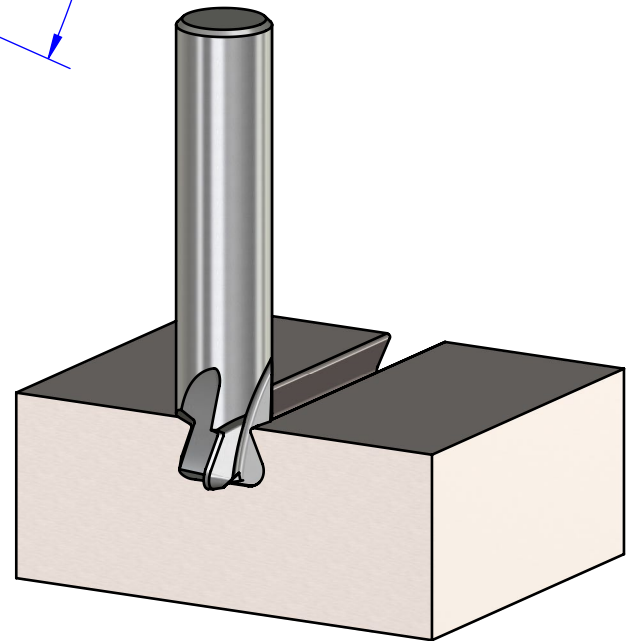

Basic Prices		
Major ϕ	1 tool	2 tools
Up to .250	\$160.	\$135. ea
.251 thru .375	\$195.	\$150. ea
.376 thru .500	\$235.	\$165. ea
.501 thru .625	\$325.	\$240. ea
.626 thru .750	\$360.	\$265. ea



Phone 916 408-2442 FAX 916 408-0740

A. B. TOOLS, INC.
1051 Aviation Blvd.
Lincoln, CA, 95648-9312

If any product is not satisfactory
we will modify, replace or refund.

Toll free phone 866 440-8665

www.abtoolsinc.com
E-Mail: mail@abtoolsinc.com

Solid Carbide DSP Cutters for protective cable grooves

Number	"G"	"N"	"F"	"V"	Shank Ø	OAL	Flutes	Price
DSP-02	.047	.023	.0125	.026	3/16	2	2	\$70.
DSP-03	.064	.036	.021	.034	3/16	2	2	\$70.
DSP-04B	.095	.045	.022	.049	3/16	2	2	\$75.
DSP-070	.095	.053	.0325	.054	3/16	2	2	\$75.
DSP-05B	.110	.059	.035	.062	3/16	2	2	\$75.
DSP-06	.126	.071	.0455	.075	3/16	2	2	\$80.
DSP-103	.142	.077	.048	.084	3/16	2	2	\$80.
DSP-07B	.157	.079	.0485	.094	3/16	2	2	\$80.
DSP-08	.172	.096	.060	.100	3/16	2	2	\$80.
DSP-139	.188	.113	.0715	.105	1/4	2	2	\$90.
DSP-09	.188	.105	.0705	.119	1/4	2	2	\$90.
DSP-11	.235	.129	.0835	.144	1/4	2	2	\$90.
DSP-12	.251	.147	.093	.144	3/8	2.5	2	\$100.
DSP-16	.344	.185	.128	.229	3/8	2.5	2	\$100.
DSP-20	.407	.233	.164	.269	1/2	2.5	3	\$110.
DSP-24	.501	.280	.196	.333	1/2	2.5	3	\$165.
DSP-32	.657	.377	.267	.437	3/4	3	4	\$225.

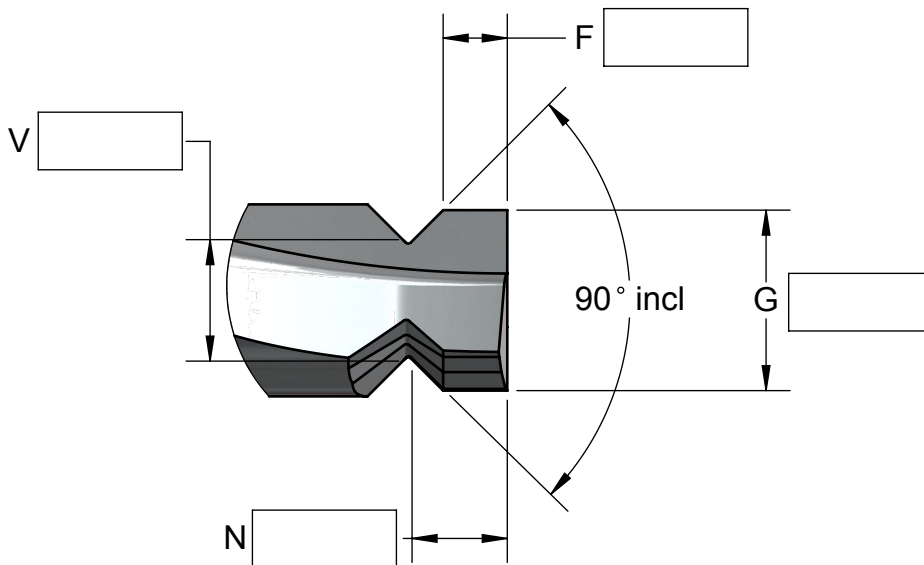

Specials in 4-6
Working Days

Multi Seal Solid Carbide DMSP Cutter

Number	"G"	"N"	"F"	"V"	Shank Ø	OAL	Flutes	Price
DMSP-04	.187	.051	.016	.117	3/16	2	2	\$80.
DMSP-06	.250	.074	.028	.159	3/8	2.5	2	\$90.
DMSP-08	.313	.086	.044	.229	3/8	2.5	3	\$100.
DMSP-12	.500	.145	.063	.336	1/2	2.5	3	\$165.
DMSP-16	.625	.192	.106	.454	5/8	3.5	4	\$195.

Phone 916 408-2442 FAX 916 408-0740

Toll free phone 866 440-8665



A. B. TOOLS, INC.
1051 Aviation Blvd.
Lincoln, CA, 95648-9312

If any product is not satisfactory
we will modify, replace or refund.

www.abtoolsinc.com
E-Mail: mail@abtoolsinc.com

Solid Carbide Dovetail Cutters

1/8" Major Ø x 1.5" OAL. With 1/8" Neck Length. 3 Flutes.

Number	A°	Cut Lngth	Neck Ø	Flat	Price	AlTiN
DS1/8-10	10	.188	.090	.001	\$58.50	\$62.
DS1/8-20	20	.125	.080	.001	\$58.50	\$62.
DS1/8-30	30	.090	.075	.001	\$58.50	\$62.
DS1/8-40	40	.080	.065	.001	\$58.50	\$62.
DS1/8-45	45	.070	.065	.001	\$58.50	\$62.
DS1/8-50	50	.065	.065	.002	\$58.50	\$62.
DS1/8-60	60	.050	.065	.002	\$58.50	\$62.
DS1/8-70	70	.040	.065	.002	\$58.50	\$62.
DS1/8-80	80	.035	.065	.002	\$58.50	\$62.
DS1/8-90	90	.030	.065	.002	\$58.50	\$62.
DS1/8-100	100	.025	.065	.003	\$58.50	\$62.
DS1/8-120	120	.020	.065	.003	\$58.50	\$62.

3/16" Major Ø x 2" OAL. With 1/8" Neck Length. 3 Flutes.

Number	A°	Cut Lngth	Neck Ø	Flat	Price	AlTiN
DS3/16-10	10	.270	.140	.001	\$60.	\$63.
DS3/16-20	20	.210	.110	.001	\$60.	\$63.
DS3/16-30	30	.160	.100	.001	\$60.	\$63.
DS3/16-40	40	.130	.090	.001	\$60.	\$63.
DS3/16-45	45	.115	.090	.001	\$60.	\$63.
DS3/16-50	50	.100	.090	.002	\$60.	\$63.
DS3/16-60	60	.080	.090	.002	\$60.	\$63.
DS3/16-70	70	.070	.090	.002	\$60.	\$63.
DS3/16-80	80	.055	.090	.002	\$60.	\$63.
DS3/16-90	90	.050	.090	.002	\$60.	\$63.
DS3/16-100	100	.040	.090	.003	\$60.	\$63.
DS3/16-120	120	.030	.090	.003	\$60.	\$63.

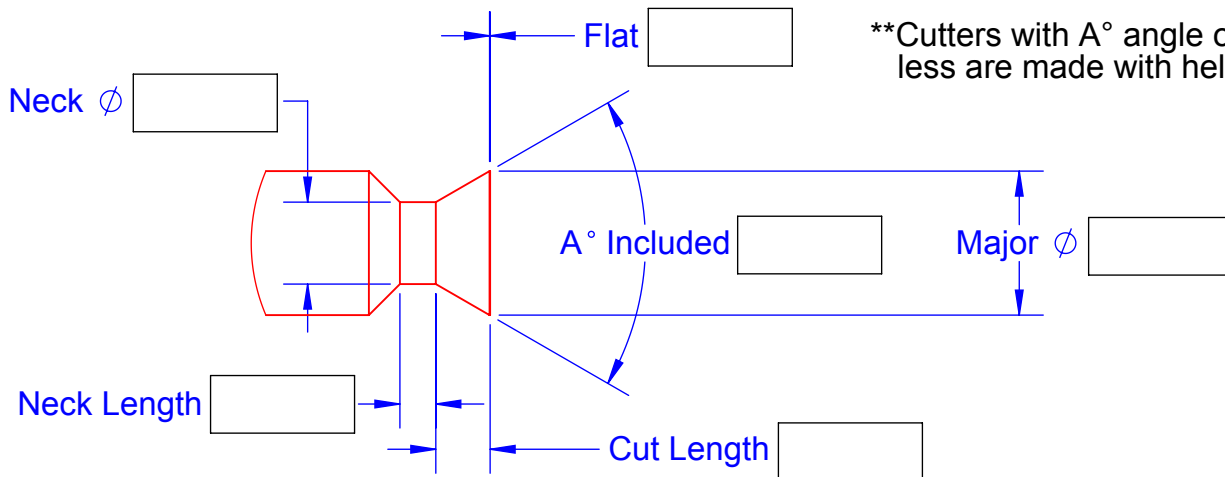

Cutters with A° angle of 45° and less are made with helical flutes.

1/4" Major Ø x 2" OAL. With 1/8" Neck Length. 3 Flutes.

Number	A°	Cut Lngth	Neck Ø	Flat	Price	AlTiN
DS1/4-10	10	.320	.160	.001	\$62.	\$67.
DS1/4-20	20	.300	.130	.001	\$62.	\$67.
DS1/4-30	30	.250	.115	.001	\$62.	\$67.
DS1/4-40	40	.190	.110	.001	\$62.	\$67.
DS1/4-45	45	.165	.110	.001	\$62.	\$67.
DS1/4-50	50	.150	.110	.002	\$62.	\$67.
DS1/4-60	60	.120	.110	.002	\$62.	\$67.
DS1/4-70	70	.100	.110	.002	\$62.	\$67.
DS1/4-80	80	.085	.110	.002	\$62.	\$67.
DS1/4-90	90	.075	.110	.002	\$62.	\$67.
DS1/4-100	100	.060	.110	.003	\$62.	\$67.
DS1/4-120	120	.045	.110	.003	\$62.	\$67.

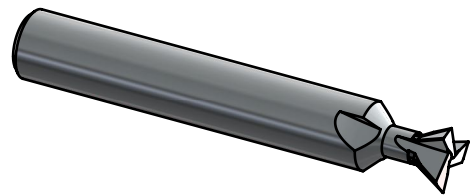

Specials in 4-6 Working Days

Phone 916 408-2442 FAX 916 408-0740

Toll free phone 866 440-8665



A. B. TOOLS, INC.
1051 Aviation Blvd.
Lincoln, CA, 95648-9312

If any product is not satisfactory we will modify, replace or refund.

www.abtoolsinc.com
E-Mail: mail@abtoolsinc.com

Solid Carbide Dovetail Cutters

3/8" Major Ø x 2.5" OAL. With 3/16" Neck Length. 3 Flutes.

Number	A°	Cut Lngth	Neck Ø	Flat	Price	AITiN
DS3/8-10	10	.370	.260	.001	\$76.	\$82.
DS3/8-20	20	.370	.230	.001	\$76.	\$82.
DS3/8-30	30	.370	.170	.001	\$76.	\$82.
DS3/8-40	40	.260	.170	.001	\$76.	\$82.
DS3/8-45	45	.235	.170	.001	\$76.	\$82.
DS3/8-50	50	.210	.170	.002	\$76.	\$82.
DS3/8-60	60	.180	.170	.002	\$76.	\$82.
DS3/8-70	70	.145	.170	.002	\$76.	\$82.
DS3/8-80	80	.130	.160	.002	\$76.	\$82.
DS3/8-90	90	.110	.160	.002	\$76.	\$82.
DS3/8-100	100	.090	.160	.003	\$76.	\$82.
DS3/8-120	120	.060	.160	.003	\$76.	\$82.

1/2" Major Ø x 2.5" OAL. With 3/16" Neck Length. 3 Flutes.

Number	A°	Cut Lngth	Neck Ø	Flat	Price	AITiN
DS1/2-10	10	.500	.360	.001	\$86.	\$94.
DS1/2-20	20	.400	.300	.001	\$86.	\$94.
DS1/2-30	30	.320	.200	.001	\$86.	\$94.
DS1/2-40	40	.320	.180	.001	\$86.	\$94.
DS1/2-45	45	.320	.180	.001	\$86.	\$94.
DS1/2-50	50	.320	.180	.002	\$86.	\$94.
DS1/2-60	60	.250	.180	.002	\$86.	\$94.
DS1/2-70	70	.210	.180	.002	\$86.	\$94.
DS1/2-80	80	.180	.180	.002	\$86.	\$94.
DS1/2-90	90	.140	.180	.002	\$86.	\$94.
DS1/2-100	100	.120	.180	.003	\$86.	\$94.
DS1/2-120	120	.090	.180	.003	\$86.	\$94.

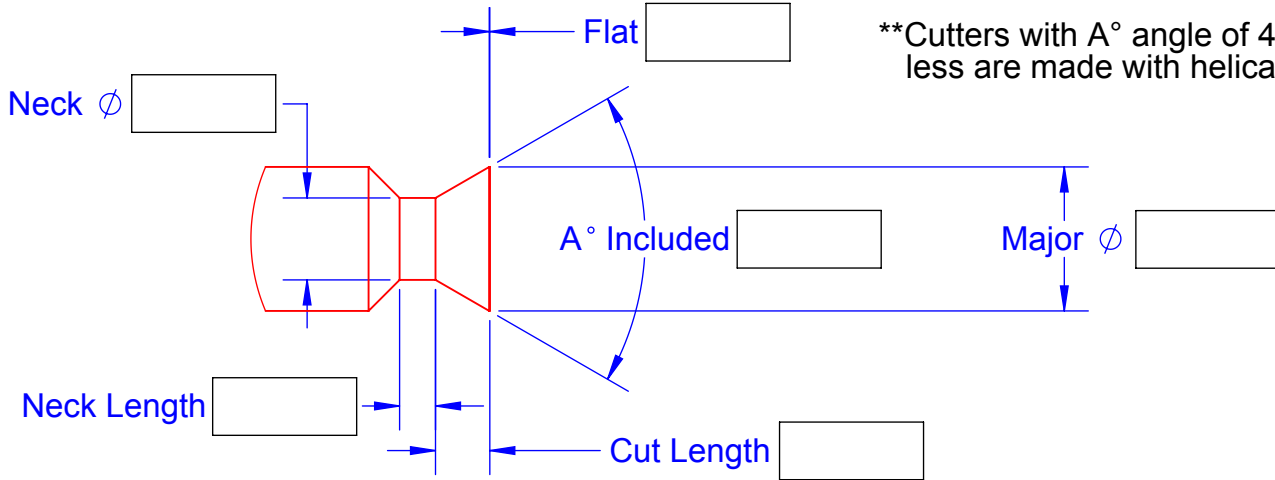

Cutters with A° angle of 45° and less are made with helical flutes.

5/8" Major Ø x 3" OAL. With 3/16" Neck Length. 4 Flutes.

Number	A°	Cut Lngth	Neck Ø	Flat	Price	AITiN
DS5/8-10	10	.600	.500	.001	\$125.	\$134.
DS5/8-20	20	.500	.440	.001	\$125.	\$134.
DS5/8-30	30	.450	.360	.001	\$125.	\$134.
DS5/8-40	40	.400	.330	.001	\$125.	\$134.
DS5/8-45	45	.350	.330	.001	\$125.	\$134.
DS5/8-50	50	.310	.330	.002	\$125.	\$134.
DS5/8-60	60	.250	.330	.002	\$125.	\$134.
DS5/8-70	70	.210	.330	.002	\$125.	\$134.
DS5/8-80	80	.185	.310	.002	\$125.	\$134.
DS5/8-90	90	.150	.310	.002	\$125.	\$134.
DS5/8-100	100	.130	.310	.003	\$125.	\$134.
DS5/8-120	120	.090	.310	.003	\$125.	\$134.

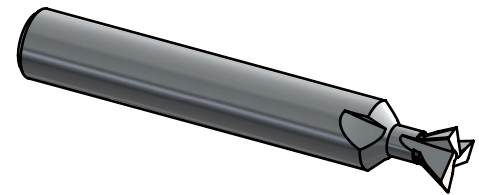

Specials in 4-6 Working Days



Phone 916 408-2442 FAX 916 408-0740

A. B. TOOLS, INC.
1051 Aviation Blvd.
Lincoln, CA, 95648-9312

If any product is not satisfactory we will modify, replace or refund.

Toll free phone 866 440-8665

www.abtoolsinc.com
E-Mail: mail@abtoolsinc.com

Solid Carbide Corner Rounders

CNC Profile Ground, Double End

The Major Cut Dia. equals
the Minor Dia. + (R. X 2) + .020

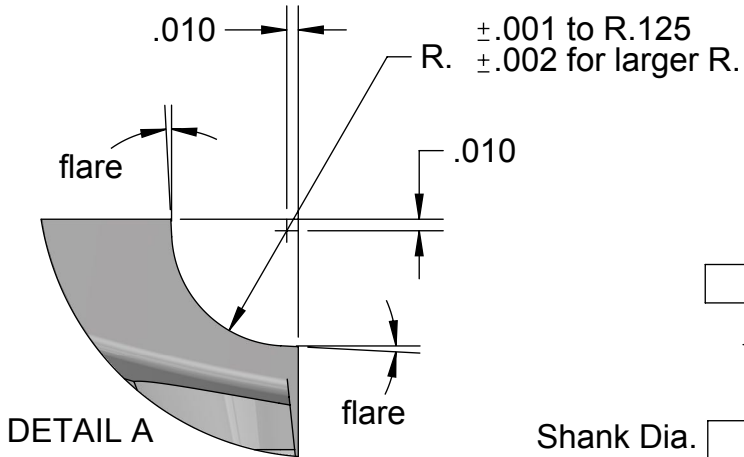
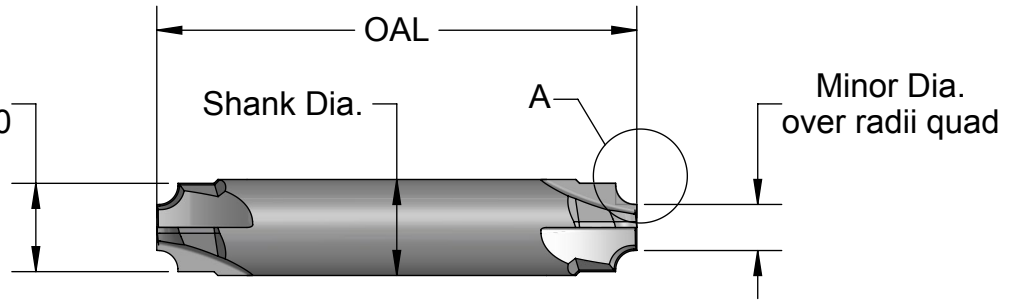

**Special Corner Rounders
in 4-6 working days**
Machining what part
material, please?

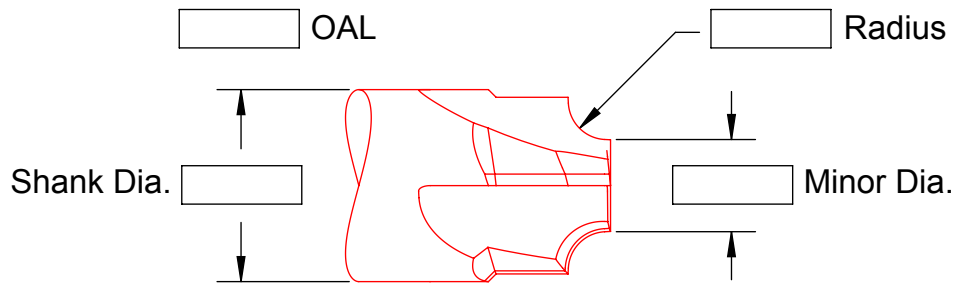

All AB Tools corner rounders
are made with these features
to avoid gouging.

Tool No.	(add R. to prefix, example CR12-031) Radius Sizes Available	Minor Dia.	No. Flutes	Shank & OAL	Prices	
					No-Coat	AlTiN
CR1-___	.010 .013 .015 .018 .020 .022 .025 .028 .031			3/8 x 2.5	\$90.	\$104.
	.035 .038 .040 .046 .048 .050 .055					
CR2-___	.062 .070 .078 .080 .085 .093 .098 .100 .109 .118 .120 .125	.240	4	1/2 x 2.5	\$100.	\$118.
	.140 .156 .170 .187 .197			5/8 x 3.5	\$170.	\$194.
				.203 .218 .234 .250	3/4 x 4.0	\$200.
CR03-___	.010 .015 .020 .025 .031 .040 .046 .050 .055	.030	2	3/16 x 2	\$60.	\$67.
	.062 .070 .078					
CR06-___	.010 .013 .015 .018 .020 .022 .025 .028 .031 .035 .040	.060	2	3/16 x 2	\$60.	\$67.
	.046 .048 .050 .055 .060					
CR12-___	.010 .013 .015 .018 .020 .022 .025 .028 .031	.120	2	1/4 x 2	\$70.	\$78.
	.035 .038 .040 .046 .048 .050 .055 .060					
CR18-___	.015 .020 .031 .035 .046 .055 .062 .070 .078 .080	.180	3	3/8 x 2.5	\$90.	\$104.
	.085 .093 .098 .109 .118 .120 .125 .130 .140 .150 .156			1/2 x 2.5	\$100.	\$118.
				.170 .180 .187 .197 .203 .218	5/8 x 3.5	\$170.
	.234 .250				3/4 x 4.0	\$200.



Phone 916 408-2442 FAX 916 408-0740

A. B. TOOLS, INC.
1051 Aviation Blvd.
Lincoln, CA, 95648-9312

If any product is not satisfactory
we will modify, replace or refund.

Toll free phone 866 440-8665

www.abtoolsinc.com
E-Mail: mail@abtoolsinc.com

Carbide Tipped Corner Rounders

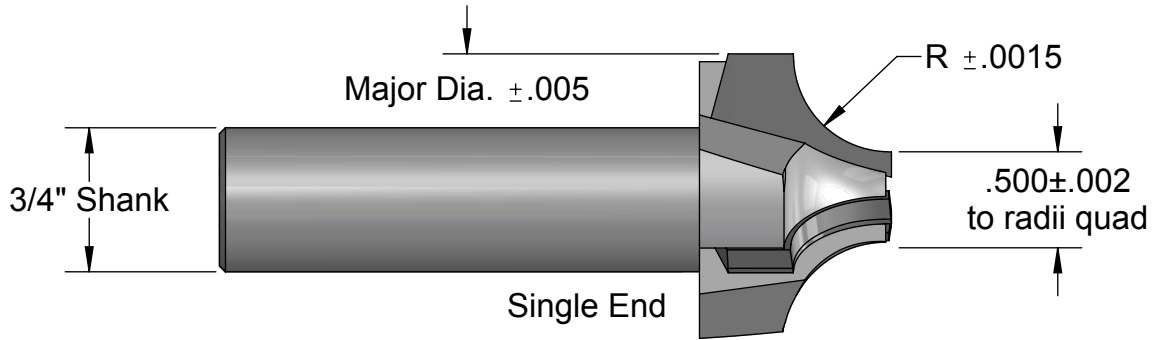

Special Carbide Tipped Corner Rounders in 4-6 working days

Machining what part material, please? _____

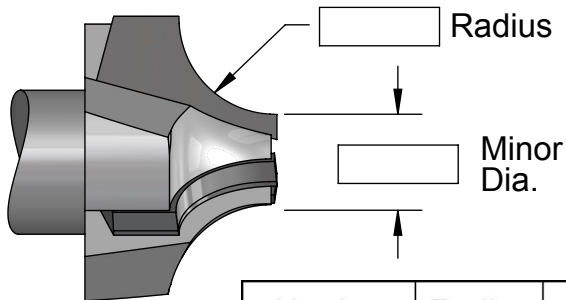

All AB Tools corner rounders are made with these features to avoid gouging.

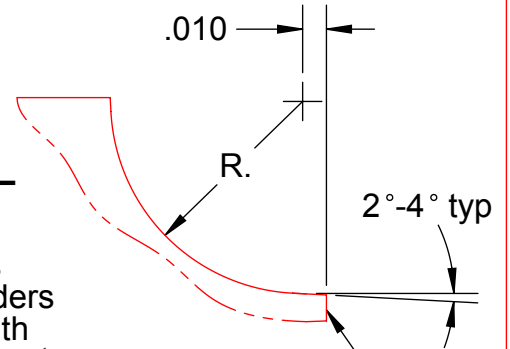

End Cutting, also the major Dia. is cutting for 1/8 min.

Number	Radius	Major Dia.	OAL	Price	
				No-Coat	AlTiN
3 Flutes, Positive Rake					
CR3-187	.187	.895	3.25	\$195.	\$215.
CR3-203	.203	.926		\$205.	\$225.
CR3-218	.218	.956		\$220.	\$240.
CR3-250	.250	1.020		\$225.	\$248.
CR3-281	.281	1.082		\$240.	\$263.
CR3-312	.312	1.144		\$250.	\$273.
CR3-343	.343	1.206		\$270.	\$293.
CR3-375	.375	1.270		\$295.	\$320.
CR3-406	.406	1.332		\$310.	\$335.
CR3-437	.437	1.394		\$320.	\$345.
CR3-468	.468	1.456		\$335.	\$360.
CR3-500	.500	1.520	\$355.	\$386.	
CR3-562	.562	1.644	3.50	\$380.	\$411.
CR3-625	.625	1.770		\$425.	\$521.

Phone 916 408-2442 FAX 916 408-0740

Toll free phone 866 440-8665



A. B. TOOLS, INC.
1051 Aviation Blvd.
Lincoln, CA, 95648-9312

If any product is not satisfactory
we will modify, replace or refund.

www.abtoolsinc.com
E-Mail: mail@abtoolsinc.com

Large Radii M42 Cobalt Corner Rounders

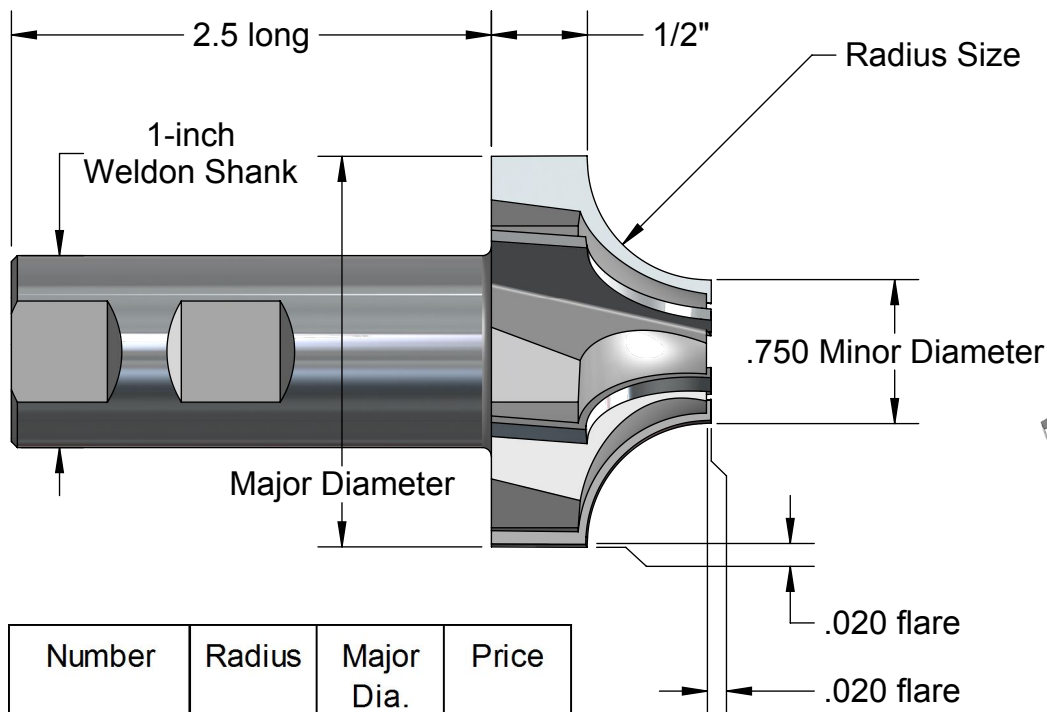

Number	Radius	Major Dia.	Price
CCR-625	.625	2.04	\$475.
CCR-687	.687	2.16	\$485.
CCR-719	.719	2.23	\$500.
CCR-750	.750	2.29	\$525.
CCR-787	.787	2.36	\$525.
CCR-812	.812	2.41	\$550.
CCR-875	.875	2.54	\$550.
CCR-937	.937	2.66	\$575.
CCR-984	.984	2.76	\$575.
CCR-1000	1.000	2.79	\$595.
CCR-1063	1.063	2.91	\$595.
CCR-1125	1.125	3.04	\$615.
CCR-1181	1.181	3.15	\$615.
CCR-1250	1.250	3.29	\$650.
CCR-1312	1.312	3.41	\$695.
CCR-1375	1.375	3.54	\$750.
CCR-1437	1.437	3.66	\$815.
CCR-1500	1.500	3.79	\$875.

We've milled full radius cuts with these Corner Rounders in M2 HSS at 90 SFM and .0015 Inch Per Tooth Chip Load with GREAT results

***Coatings available upon request.



Phone 916 408-2442 FAX 916 408-0740

A. B. TOOLS, INC.
1051 Aviation Blvd.
Lincoln, CA, 95648-9312

If any product is not satisfactory
we will modify, replace or refund.

Toll free phone 866 440-8665

www.abtoolsinc.com
E-Mail: mail@abtoolsinc.com

Solid Carbide TOP & BOTTOM Corner Rounders

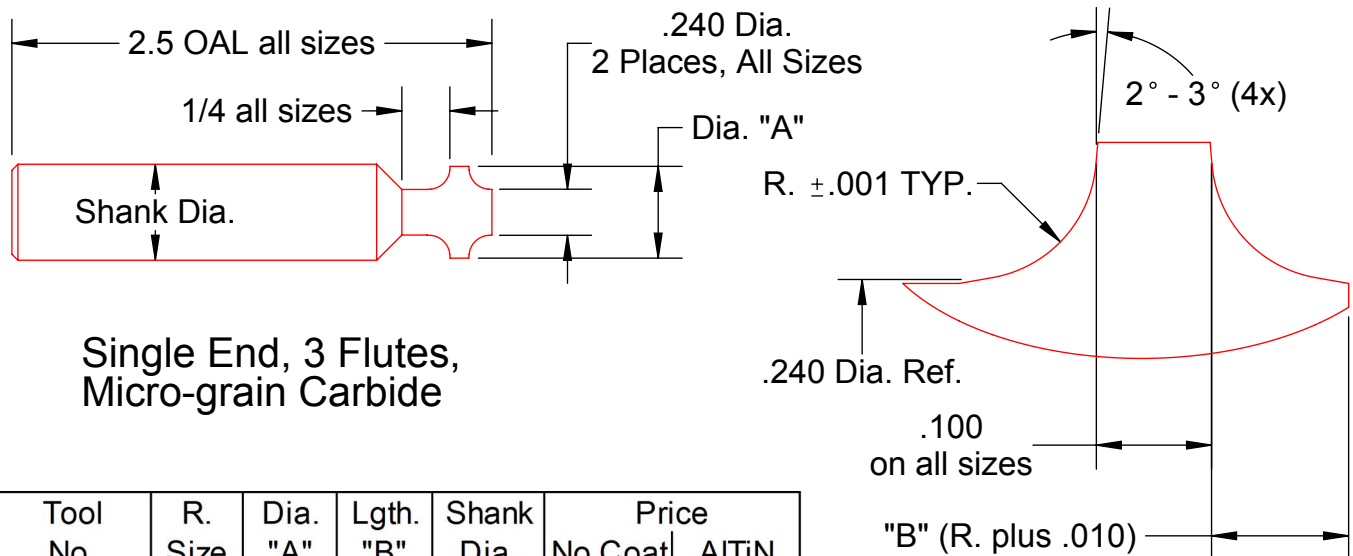
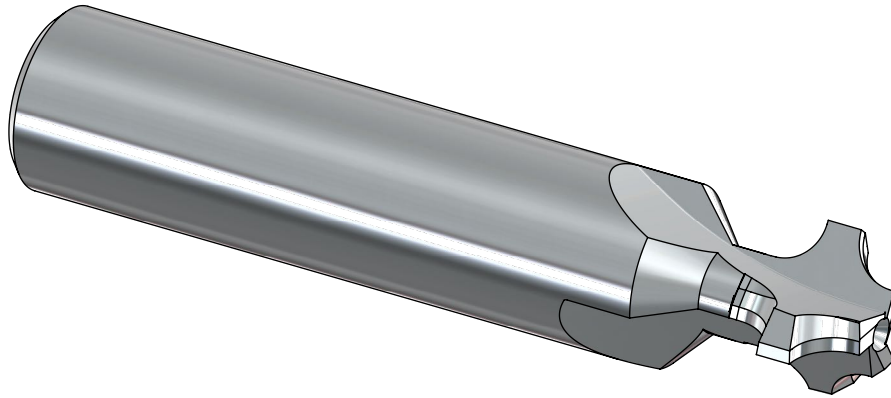

Single End, 3 Flutes,
Micro-grain Carbide

Tool No.	R. Size	Dia. "A"	Lgth. "B"	Shank Dia.	Price	
					No Coat	AlTiN
CRD-015	.015	.290	.025	3/8	\$135.	\$142.
CRD-020	.020	.300	.030	3/8	\$135.	\$142.
CRD-031	.031	.322	.041	3/8	\$135.	\$142.
CRD-040	.040	.340	.050	3/8	\$135.	\$142.
CRD-046	.046	.352	.056	3/8	\$135.	\$142.
CRD-062	.062	.384	.072	1/2	\$150.	\$159.
CRD-078	.078	.416	.088	1/2	\$150.	\$159.
CRD-093	.093	.446	.103	1/2	\$150.	\$159.
CRD-109	.109	.478	.119	1/2	\$150.	\$159.
CRD-125	.125	.510	.135	1/2	\$150.	\$159.

**Specials in 4-6
Working Days**



Phone 916 408-2442 FAX 916 408-0740

A. B. TOOLS, INC.
1051 Aviation Blvd.
Lincoln, CA, 95648-9312

If any product is not satisfactory
we will modify, replace or refund.

Toll free phone 866 440-8665

www.abtoolsinc.com
E-Mail: mail@abtoolsinc.com

Solid Carbide BACK Corner Rounders

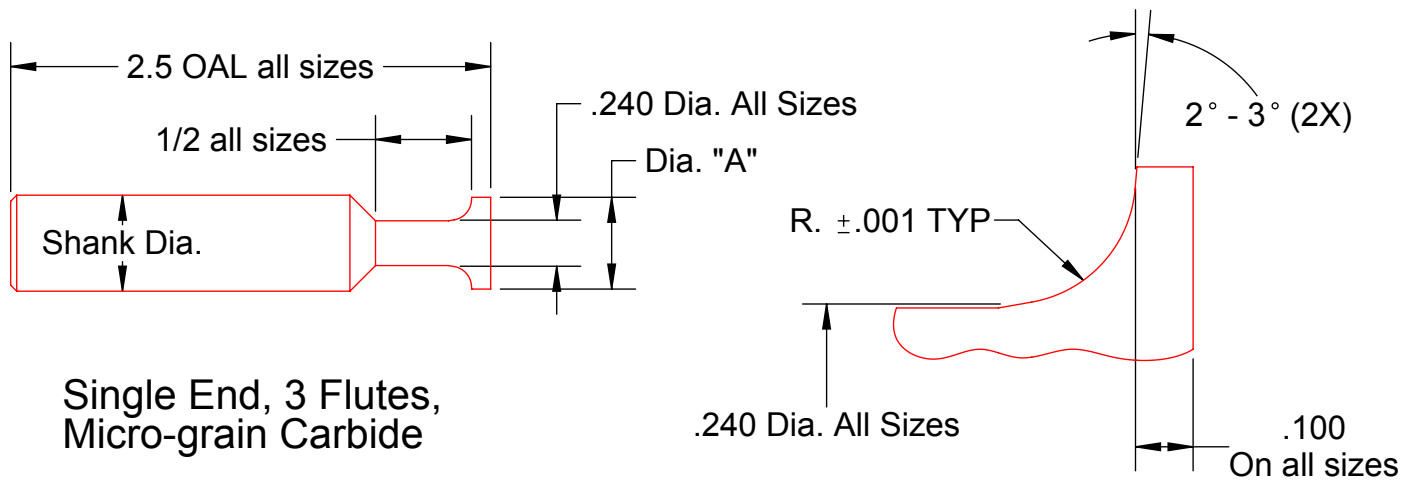
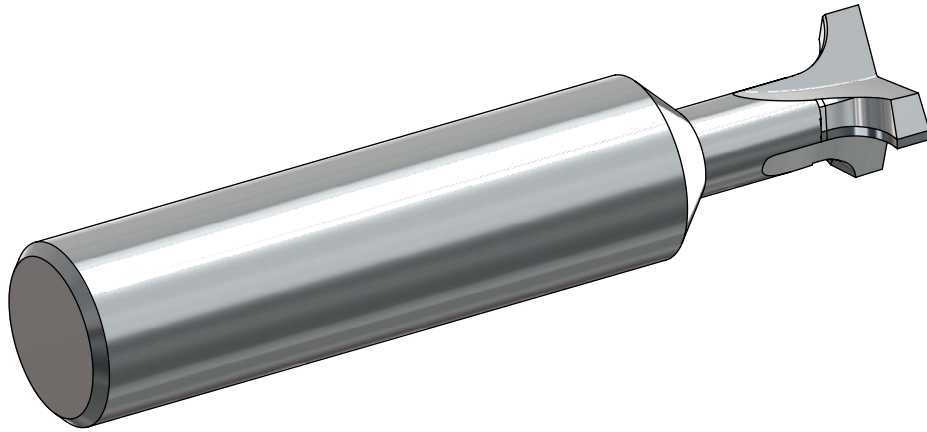

Single End, 3 Flutes,
Micro-grain Carbide

Tool No.	R. Size	Dia. "A"	Shank Dia.	Price	
				No Coat	AlTiN
BCR-015	.015	.290	3/8	\$105.	\$112.
BCR-020	.020	.300	3/8	\$105.	\$112.
BCR-031	.031	.322	3/8	\$105.	\$112.
BCR-040	.040	.340	3/8	\$105.	\$112.
BCR-046	.046	.352	3/8	\$105.	\$112.
BCR-062	.062	.384	1/2	\$115.	\$124.
BCR-078	.078	.416	1/2	\$115.	\$124.
BCR-093	.093	.446	1/2	\$115.	\$124.
BCR-109	.109	.478	1/2	\$115.	\$124.
BCR-125	.125	.510	1/2	\$115.	\$124.

**Specials in 4-6
Working Days**



Phone 916 408-2442 FAX 916 408-0740

A. B. TOOLS, INC.
1051 Aviation Blvd.
Lincoln, CA, 95648-9312

If any product is not satisfactory
we will modify, replace or refund.

Toll free phone 866 440-8665

www.abtoolsinc.com
E-Mail: mail@abtoolsinc.com

Solid Carbide Full Concave Cutters

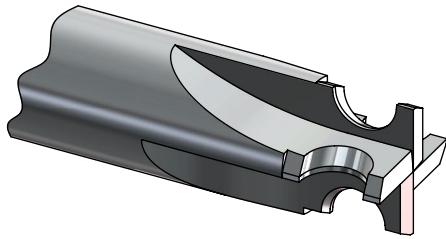

Full Form Design

Specials in 4-6 Working Days

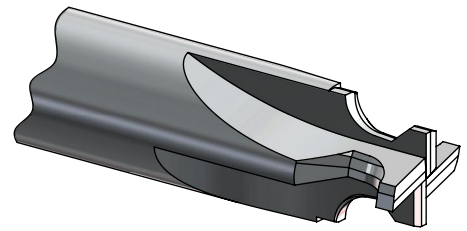

Alternating Tooth Design

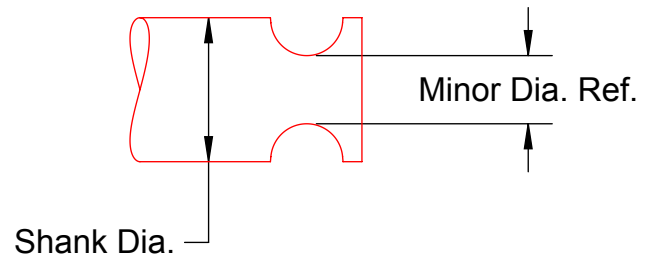
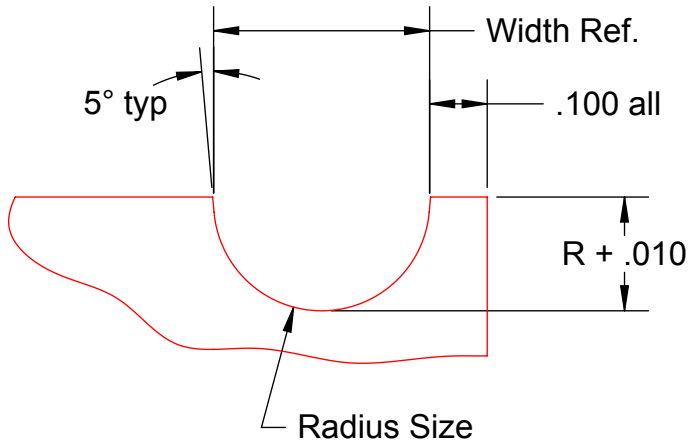

Profile ground (not formed) for rounder, more free cutting concave cutters.

Tool Number	Radius Size	Width Ref.	Shank X OAL	Number of Flutes	Minor Dia. Ref.	Price	
						No-Coat	AlTiN
FCR-031 *	.031	.062	1/2 X 2.5	6	.418	\$155.	\$164.
FCR-040 *	.040	.080	1/2 X 2.5	4	.400	\$155.	\$164.
FCR-046 *	.046	.092	1/2 X 2.5	4	.388	\$155.	\$164.
FCR-0625	.0625	.125	1/2 X 2.5	4	.355	\$165.	\$174.
FCR-079	.079	.158	1/2 X 2.5	4	.322	\$170.	\$179.
FCR-094	.094	.188	5/8 X 3.5	6	.417	\$195.	\$207.
FCR-100	.100	.200	5/8 X 3.5	4	.405	\$195.	\$207.
FCR-120	.120	.240	5/8 X 3.5	4	.365	\$200.	\$212.
FCR-125	.125	.250	5/8 X 3.5	4	.355	\$200.	\$212.
FCR-157	.157	.314	3/4 X 4.0	6	.416	\$215.	\$229.
FCR-1875	.1875	.375	3/4 X 4.0	4	.355	\$230.	\$244.
FCR-197	.197	.394	3/4 X 4.0	4	.336	\$230.	\$244.

*Cutters with smaller radii are ground with alternating tooth design

Phone 916 408-2442 FAX 916 408-0740

Toll free phone 866 440-8665



A. B. TOOLS, INC.
1051 Aviation Blvd.
Lincoln, CA, 95648-9312

If any product is not satisfactory
we will modify, replace or refund.

www.abtoolsinc.com
E-Mail: mail@abtoolsinc.com

Extended Reach, Double End, Solid Carbide, Corner Rounders

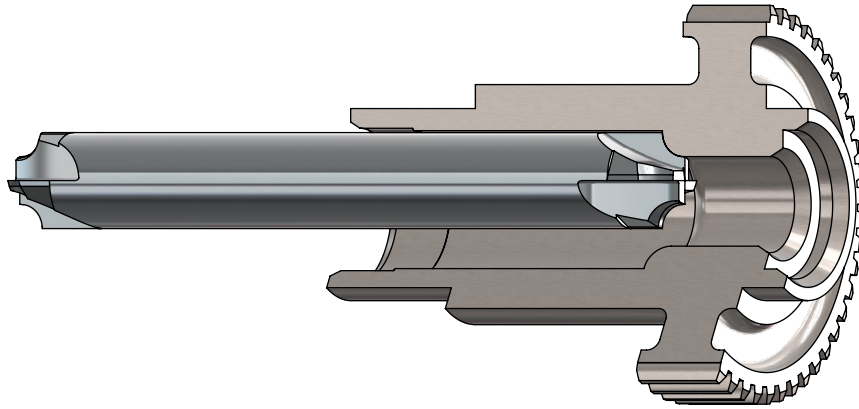

Specials in 4-6 Working Days

Radius center at shank diameter allows machining close to other features.

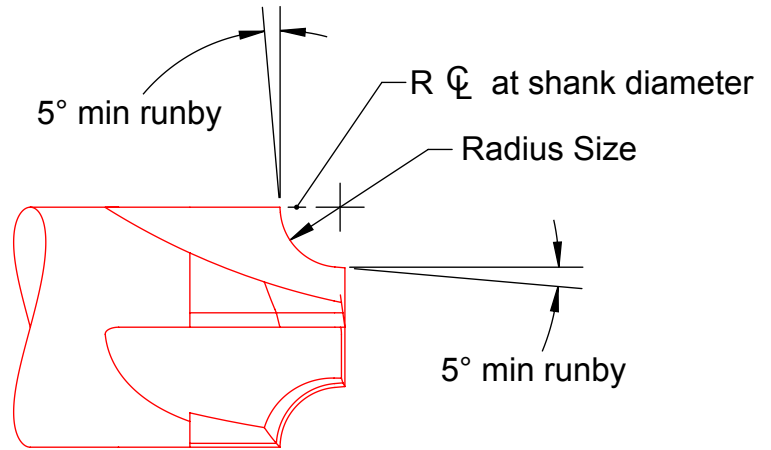

Number	Radius sizes, add to prefix, example CRL1/2-062							Shank & OAL	Flutes	Price	
CRL1/4-	.010	.015	.020	.031	.046	.062		1/4 X 3	2 or 4	\$90.	
CRL3/8-	.010	.015	.020	.031	.046	.062		3/8 X 4	2 or 4	\$110.	
	.093	.125						3/8 X 4	2 or 4		
CRL1/2-	.010	.015	.020	.031	.046	.062	.093	.125	1/2 X 4	2 or 4	\$125.
	.156	.187							1/2 X 4	2 or 4	



Phone 916 408-2442 FAX 916 408-0740

A. B. TOOLS, INC.
1051 Aviation Blvd.
Lincoln, CA, 95648-9312

If any product is not satisfactory
we will modify, replace or refund.

Toll free phone 866 440-8665

www.abtoolsinc.com
E-Mail: mail@abtoolsinc.com

Solid Carbide Thread Mills

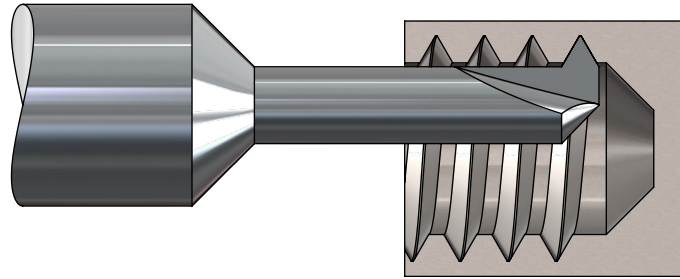

With these 11 cutters you can mill Coarse or Fine threads from No. 3 thru 3/4 and from 2MM thru 24MM

Number	For Sizes (NC & NF)		Cut Dia.	Crest	Neck Dia.	Neck* Length	Shank & OAL	No. of Flutes	Price	
									No-Coat	AlTiN
TM3	#3	2MM	.072	.001	.040	.160	3/16 X 2	1	\$65.	\$68.
TM4	#4	3MM	.083	.001	.045	.190	3/16 X 2	1	\$65.	\$68.
	#5	3.5MM								
TM6	#6	4MM	.099	.0015	.055	.260	3/16 X 2	2	\$65.	\$68.
TM8	#8	4.5MM	.128	.002	.083	.320	3/16 X 2	3	\$70.	\$73.
TM10	#10	5MM	.139	.0025	.081	.380	3/16 X 2	3	\$70.	\$73.
TM1/4	1/4	6MM	.188	.003	.124	.400	1/4 X 2	4	\$75.	\$79.
TM5/16	5/16	8MM	.247	.003	.175	.500	3/8 X 2.5	4	\$80.	\$87.
TM3/8	3/8	10MM	.300	.003	.218	.600	3/8 X 2.5	4	\$85.	\$92.
TM1/2	1/2	16MM	.420	.0035	.300	.800	1/2 X 2.5	6	\$100.	\$109.
TM5/8	5/8	20MM	.500	.0026	.307	1.00	5/8 X 3.5	6	\$145.	\$157.
TM3/4	3/4	24MM	.625	.0026	.416	1.25	3/4 X 4	6	\$195.	\$209.

*Necks ground longer on request with minimal charges based upon quantity

Special Thread Mills in 4-6 Working Days
Machining what part material, please?

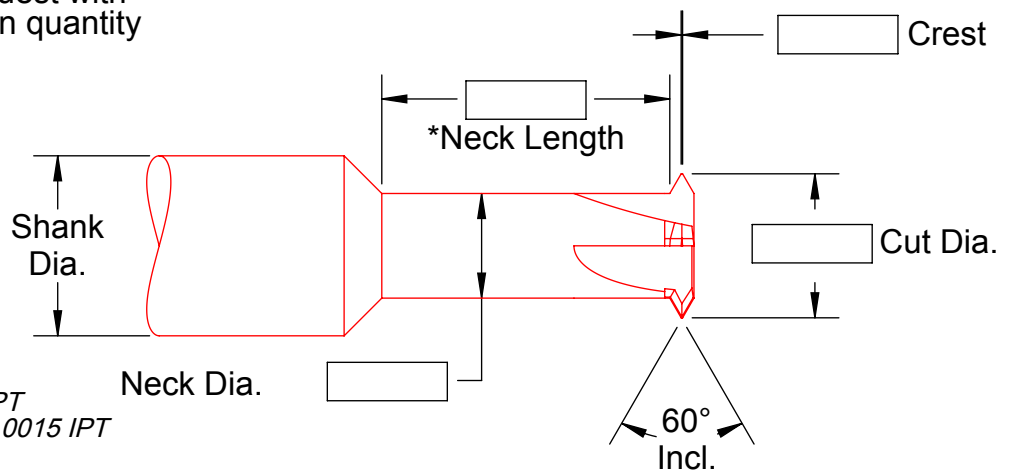

Suggested Starting Date:
Ferrous 150/300 SFM; .0002/.001 IPT
Non-Ferrous 500/1000 SFM; .0005/.0015 IPT
Interpolate helix from bottom up.

Phone 916 408-2442 FAX 916 408-0740

Toll free phone 866 440-8665



A. B. TOOLS, INC.
1051 Aviation Blvd.
Lincoln, CA, 95648-9312

If any product is not satisfactory we will modify, replace or refund.

www.abtoolsinc.com
E-Mail: mail@abtoolsinc.com

Solid Carbide Internal Thread Relief Mills

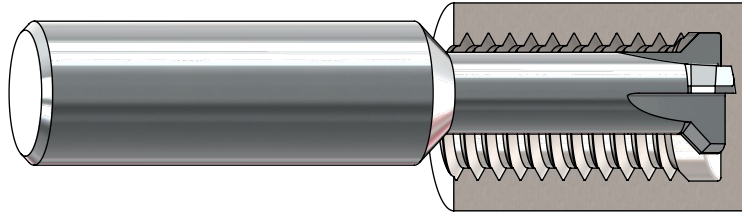

Number	Dia.	Flat	Rad.	Neck Dia.	Neck Length	Shank Dia.	OAL	No. of Flutes	Price	
									No-Coat	AlTiN
TR3-48	.072	.021	.005	.032	.180	3/16	2	2	\$65.	\$68.
TR4-40	.080	.025	.005	.032	.210	3/16	2	2	\$65.	\$68.
TR6-32	.099	.031	.010	.047	.290	3/16	2	2	\$65.	\$68.
TR8-32	.128	.031	.010	.076	.330	3/16	2	3	\$65.	\$68.
TR10-24	.139	.042	.012	.073	.410	3/16	2	3	\$65.	\$68.
TR1/4-20	.188	.050	.012	.108	.435	1/4	2	4	\$70.	\$74.
TR5/16-18	.247	.056	.012	.159	.538	3/8	2-1/2	4	\$75.	\$82.
TR3/8-16	.300	.063	.012	.202	.641	3/8	2-1/2	4	\$85.	\$92.
TR1/2-13	.420	.077	.012	.284	.848	1/2	2-1/2	6	\$95.	\$104.

*Necks ground longer on request with minimal charges based upon quantity

Undercut diameter:
 Pitches finer than 20 TPI = thread basic major dia + .0075
 Pitches of 20 TPI and courser = thread basic major dia + .0150

Special Thread Relief Mills Made in 4-6 Working Days

Machining what part material, please? _____

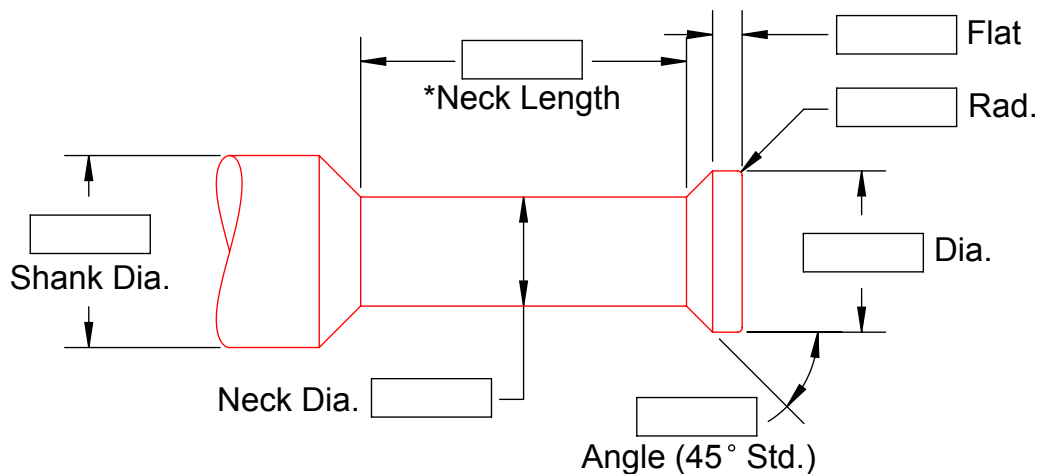

Phone 916 408-2442 FAX 916 408-0740

Toll free phone 866 440-8665



A. B. TOOLS, INC.
 1051 Aviation Blvd.
 Lincoln, CA, 95648-9312

If any product is not satisfactory
 we will modify, replace or refund.

www.abtoolsinc.com
 E-Mail: mail@abtoolsinc.com

Bevel Cutters, Solid Carbide, In Stock.

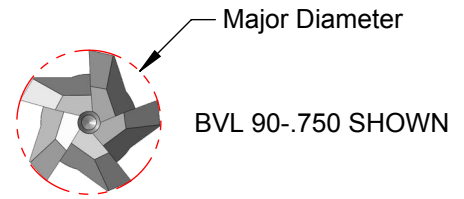
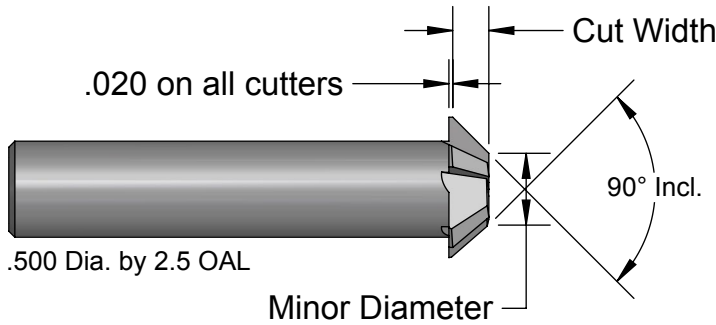

Specials in 4-6 Working Days

90° Included Angles

Number	Major Diameter	Minor Diameter	Cut Width	Number of Flutes	Price
BVL 90-.500	.500	.250	.125	4	\$100.
BVL 90-.750	.750	.375	.188	5	\$125.
BVL 90-1.00	1.000	.375	.312	6	\$145.
BVL 90-1.25	1.250	.500	.375	8	\$165.
BVL 90-1.50*	1.500	.500	.500	10	\$195.

60° Included Angles

Number	Major Diameter	Minor Diameter	Cut Width	Number of Flutes	Price
BVL 60-.500	.500	.246	.220	4	\$100.
BVL 60-.750	.750	.390	.312	5	\$125.
BVL 60-1.00	1.000	.503	.430	6	\$145.
BVL 60-1.25*	1.250	.673	.500	8	\$185.
BVL 60-1.50*	1.500	.778	.625	10	\$195.

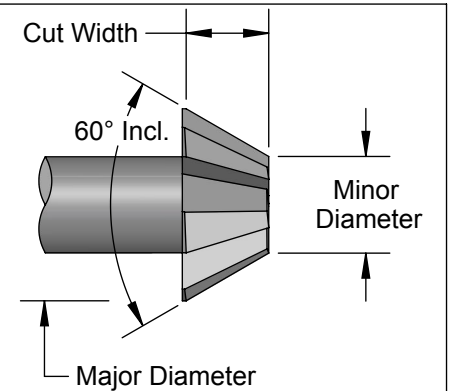

120° Included Angles

Number	Major Diameter	Minor Diameter	Cut Width	Number of Flutes	Price
BVL 120-.500	.500	.188	.090	4	\$100.
BVL 120-.750	.750	.317	.125	5	\$125.
BVL 120-1.00	1.000	.350	.188	6	\$145.
BVL 120-1.25	1.250	.488	.220	8	\$165.
BVL 120-1.50	1.500	.634	.250	10	\$195.

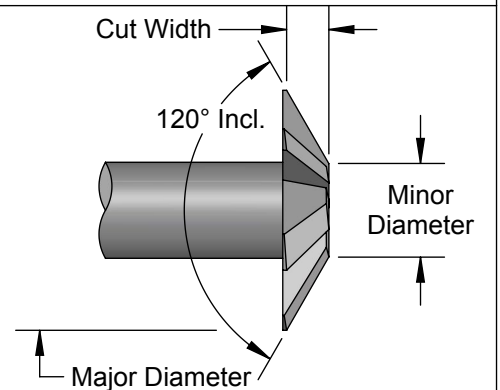

* These cutters are on 3/4" shanks and 2-3/4" OAL



Phone 916 408-2442 FAX 916 408-0740

A. B. TOOLS, INC.
1051 Aviation Blvd.
Lincoln, CA, 95648-9312

If any product is not satisfactory
we will modify, replace or refund.

Toll free phone 866 440-8665

www.abtoolsinc.com
E-Mail: mail@abtoolsinc.com

TOP & BOTTOM Chamfer Cutters

Specials in 4-6 Working Days

Machining what part material, please? _____

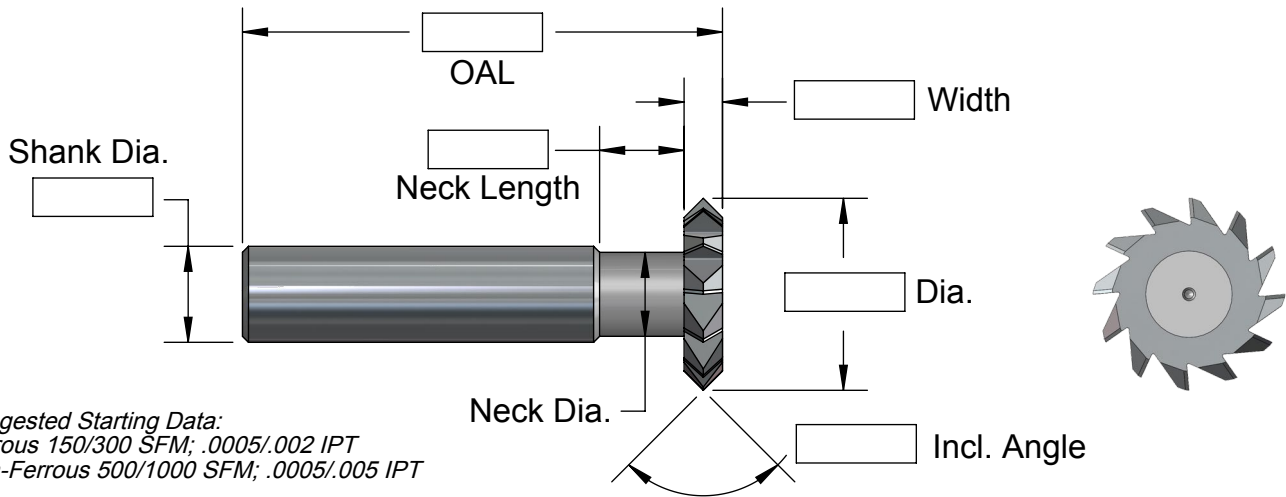

Suggested Starting Data:
 Ferrous 150/300 SFM; .0005/.002 IPT
 Non-Ferrous 500/1000 SFM; .0005/.005 IPT

Number	Dia.	Width	Neck Dia.	Neck Length	Incl. Angle	Shank & OAL	No. of Flutes	Price	
								No-Coat	AlTiN
CCD-187-90	.187	.060	.115	.38	90	3/16-2	4	\$68.	\$71.
CCD-250-90	.250	.090	.150	.44	90	1/4-2	4	\$80.	\$84.
CCD-375-90	.375	.110	.250	.50	90	3/8-2.5	6	\$95.	\$102.
CCD-500-90	.500	.125	.350	.68	90	1/2-2.5	6	\$110.	\$119.
CCD-625-90	.625	.140	.440	.75	90	1/2-2.5	8	\$130.	\$140.
CCD-750-90	.750	.170	.440	1.0	90	1/2-2.5	10	\$145.	\$157.
CCD-100-90	1.00	.200	.440	1.2	90	1/2-2.5	12	\$170.	\$184.
CCD-187-60	.187	.030	.115	.38	60	3/16-2	4	\$68.	\$71.
CCD-250-60	.250	.045	.150	.44	60	1/4-2	4	\$80.	\$84.
CCD-375-60	.375	.060	.250	.50	60	3/8-2.5	6	\$95.	\$102.
CCD-500-60	.500	.075	.350	.68	60	1/2-2.5	6	\$110.	\$119.
CCD-625-60	.625	.090	.440	.75	60	1/2-2.5	8	\$130.	\$140.
CCD-750-60	.750	.150	.440	1.0	60	1/2-2.5	10	\$145.	\$157.
CCD-100-60	1.00	.200	.440	1.2	60	1/2-2.5	12	\$170.	\$184.
CCD-187-120	.187	.060	.115	.38	120	3/16-2	4	\$68.	\$71.
CCD-250-120	.250	.090	.150	.44	120	1/4-2	4	\$80.	\$84.
CCD-375-120	.375	.110	.250	.50	120	3/8-2.5	6	\$95.	\$102.
CCD-500-120	.500	.125	.350	.68	120	1/2-2.5	6	\$110.	\$119.
CCD-625-120	.625	.140	.440	.75	120	1/2-2.5	8	\$130.	\$140.
CCD-750-120	.750	.170	.440	1.0	120	1/2-2.5	10	\$145.	\$157.
CCD-100-120	1.00	.200	.440	1.2	120	1/2-2.5	12	\$170.	\$184.

Phone 916 408-2442 FAX 916 408-0740

Toll free phone 866 440-8665



A. B. TOOLS, INC.
 1051 Aviation Blvd.
 Lincoln, CA, 95648-9312

If any product is not satisfactory
 we will modify, replace or refund.

www.abtoolsinc.com
 E-Mail: mail@abtoolsinc.com

Solid Carbide Chamfer End Mills

Specials in 4-6 Working Days

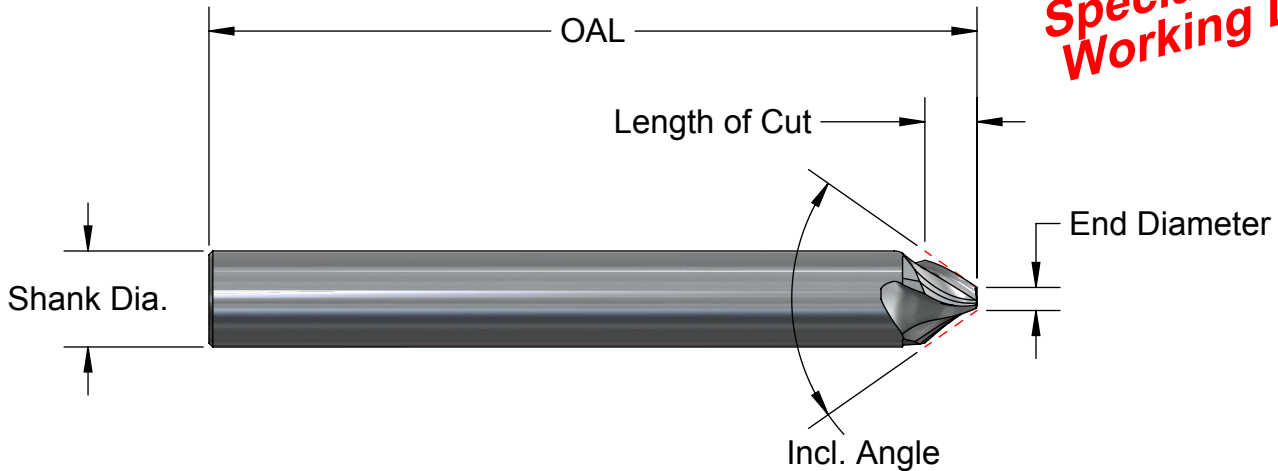

Number	End Dia.	Incl. Angle	Length of Cut	Shank X OAL	No. of Flutes	Price	
						No-Coat	AlTiN
CEM060-70	.060	70°	.136	1/4 X 2.0	3	\$75.	\$79.
CEM060-74	.060	74°	.126	1/4 X 2.0	3	\$75.	\$79.
CEM060-80	.060	80°	.113	1/4 X 2.0	3	\$75.	\$79.
CEM060-82	.060	82°	.109	1/4 X 2.0	3	\$75.	\$79.
CEM060-90	.060	90°	.095	1/4 X 2.0	3	\$75.	\$79.
CEM060-100	.060	100°	.080	1/4 X 2.0	3	\$75.	\$79.
CEM060-120	.060	120°	.091	3/8 X 2.5	3	\$80.	\$87.
CEM120-70	.120	70°	.182	3/8 X 2.5	3	\$80.	\$87.
CEM120-74	.120	74°	.169	3/8 X 2.5	3	\$80.	\$87.
CEM120-80	.120	80°	.152	3/8 X 2.5	3	\$80.	\$87.
CEM120-82	.120	82°	.147	3/8 X 2.5	3	\$80.	\$87.
CEM120-90	.120	90°	.128	3/8 X 2.5	3	\$80.	\$87.
CEM120-100	.120	100°	.107	3/8 X 2.5	3	\$80.	\$87.
CEM120-120	.120	120°	.110	1/2 X 2.5	3	\$92.	\$101.
CEM180-70	.180	70°	.229	1/2 X 2.5	3	\$92.	\$101.
CEM180-74	.180	74°	.212	1/2 X 2.5	3	\$92.	\$101.
CEM180-80	.180	80°	.191	1/2 X 2.5	3	\$92.	\$101.
CEM180-82	.180	82°	.184	1/2 X 2.5	3	\$92.	\$101.
CEM180-90	.180	90°	.160	1/2 X 2.5	3	\$92.	\$101.
CEM180-100	.180	100°	.134	1/2 X 2.5	3	\$92.	\$101.
CEM180-120	.180	120°	.128	5/8 X 3.0	3	\$105.	\$117.

Phone 916 408-2442 FAX 916 408-0740

Toll free phone 866 440-8665



A. B. TOOLS, INC.
1051 Aviation Blvd.
Lincoln, CA, 95648-9312

If any product is not satisfactory
we will modify, replace or refund.

www.abtoolsinc.com
E-Mail: mail@abtoolsinc.com

Solid Carbide Taper End Mills

(3) Flutes

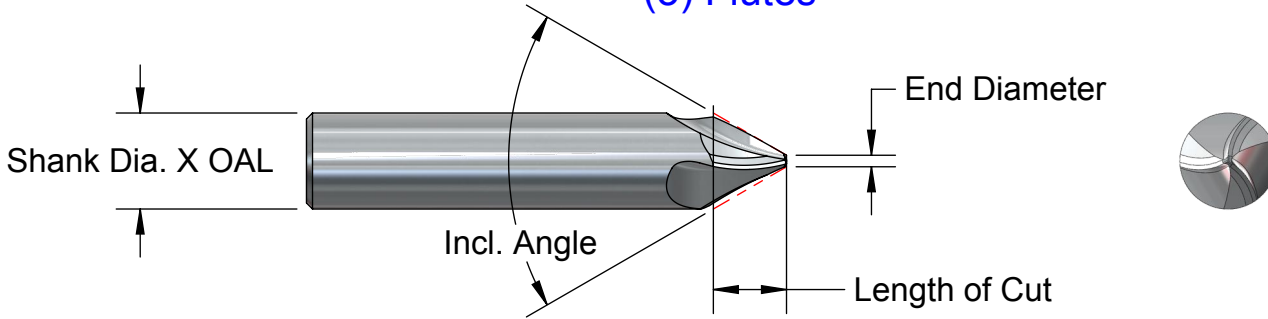

Specials in 4-6 Working Days

Number	End Dia.	Incl. Angle	Length of Cut	Shank X OAL
TEM060-10	.060	10°	.729	3/16 X 2.5
TEM060-12	.060	12°	.607	3/16 X 2.5
TEM060-15	.060	15°	.484	3/16 X 2.5
TEM060-20	.060	20°	.893	3/8 X 2.5
TEM060-25	.060	25°	.710	3/8 X 2.5
TEM060-30	.060	30°	.588	3/8 X 2.5
TEM060-35	.060	35°	.500	3/8 X 2.5
TEM060-40	.060	40°	.604	1/2 X 2.5
TEM060-45	.060	45°	.531	1/2 X 2.5
TEM060-50	.060	50°	.472	1/2 X 2.5
TEM060-60	.060	60°	.381	1/2 X 2.5

Shank X OAL	Price	
	No-Coat	AlTiN
3/16 X 2.5	\$75.	\$79.
1/4 X 2.5	\$75.	\$80.
3/8 X 2.5	\$85.	\$92.
1/2 X 2.5	\$92.	\$101.
1/2 X 3	\$95.	\$104.
1/2 X 4	\$105.	\$116.

Number	End Dia.	Incl. Angle	Length of Cut	Shank X OAL
TEM120-10	.120	10°	.743	1/4 X 2.5
TEM120-12	.120	12°	.618	1/4 X 2.5
TEM120-15	.120	15°	.494	1/4 X 2.5
TEM120-20	.120	20°	.723	3/8 X 2.5
TEM120-25	.120	25°	.575	3/8 X 2.5
TEM120-30	.120	30°	.476	3/8 X 2.5
TEM120-35	.120	35°	.404	3/8 X 2.5
TEM120-40	.120	40°	.522	1/2 X 2.5
TEM120-45	.120	45°	.459	1/2 X 2.5
TEM120-50	.120	50°	.407	1/2 X 2.5
TEM120-60	.120	60°	.329	1/2 X 2.5

Number	End Dia.	Incl. Angle	Length of Cut	Shank X OAL
TEM180-10	.180	10°	1.829	1/2 X 4
TEM180-12	.180	12°	1.522	1/2 X 4
TEM180-15	.180	15°	1.215	1/2 X 3
TEM180-20	.180	20°	.907	1/2 X 3
TEM180-25	.180	25°	.722	1/2 X 3
TEM180-30	.180	30°	.597	1/2 X 3
TEM180-35	.180	35°	.507	1/2 X 2.5
TEM180-40	.180	40°	.440	1/2 X 2.5
TEM180-45	.180	45°	.386	1/2 X 2.5
TEM180-50	.180	50°	.343	1/2 X 2.5
TEM180-60	.180	60°	.277	1/2 X 2.5

Phone 916 408-2442 FAX 916 408-0740

Toll free phone 866 440-8665



A. B. TOOLS, INC.
1051 Aviation Blvd.
Lincoln, CA, 95648-9312

If any product is not satisfactory
we will modify, replace or refund.

www.abtoolsinc.com
E-Mail: mail@abtoolsinc.com

Angle Reference

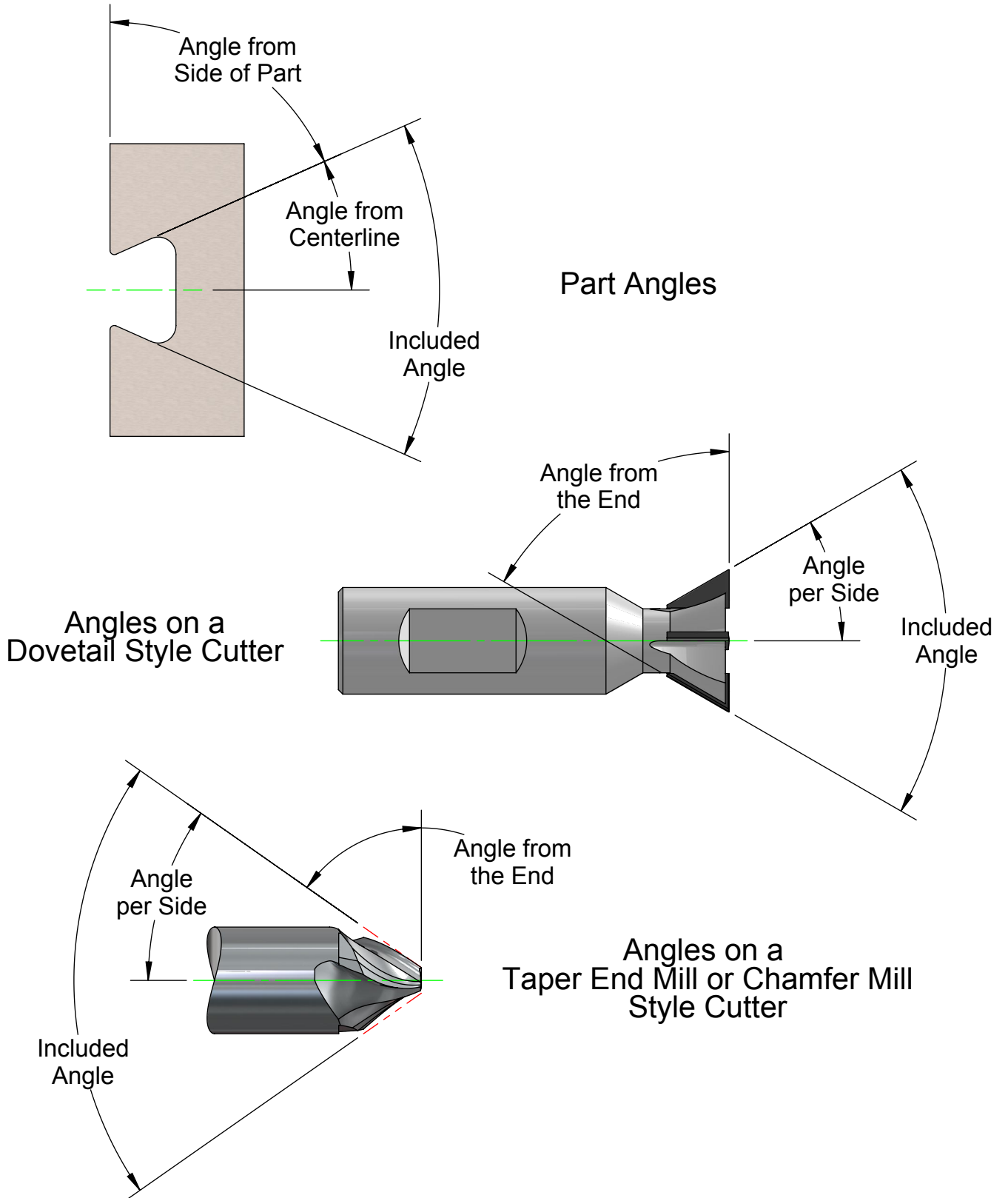

Phone 916 408-2442 FAX 916 408-0740

A. B. TOOLS, INC.
1051 Aviation Blvd.
Lincoln, CA, 95648-9312

If any product is not satisfactory
we will modify, replace or refund.

Toll free phone 866 440-8665

www.abtoolsinc.com
E-Mail: mail@abtoolsinc.com



Carbide Tipped Dovetail Cutters

Specials in 4-6 Working Days

Machining what part material, please? _____

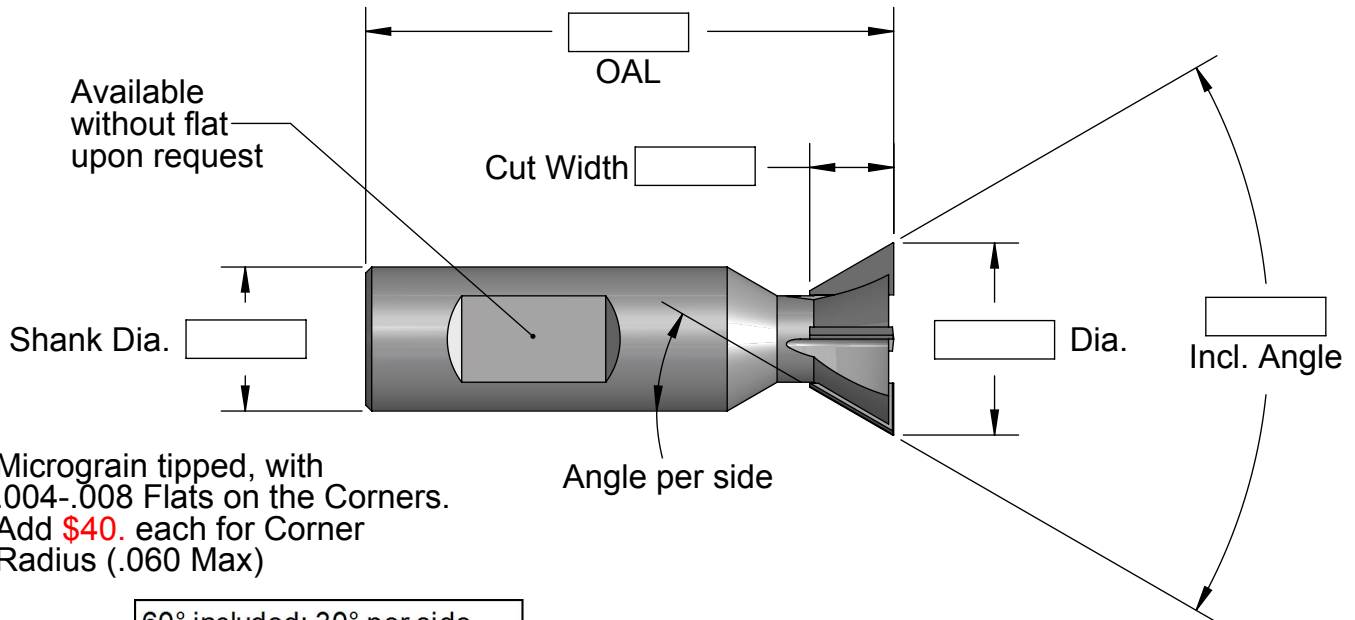

60° included; 30° per side								
Number	Incl. Angle	Dia.	Cut Width	Shank Dia.	OAL	N	Price	
							No-Coat	AlTiN
D60-.75	60°	3/4	5/16	3/4	2-3/4	3	\$180.	\$192.
D60-1.0	60°	1.00	7/16	3/4	2-3/4	4	\$190.	\$206.
D60-1.25	60°	1.25	1/2	3/4	3	5	\$200.	\$220.
D60-1.38	60°	1.38	1/2	3/4	3	6	\$200.	\$223.
D60-1.5	60°	1.50	5/8	3/4	3-1/2	6	\$255.	\$280.
D60-2.0	60°	2.00	7/8	1.0	3-3/4	8	\$290.	\$386.
D60-2.5	60°	2.50	7/8	1.0	3-3/4	8	\$370.	\$482.

90° included; 45° per side								
Number	Incl. Angle	Dia.	Cut Width	Shank Dia.	OAL	N	Price	
							No-Coat	AlTiN
D90-.75	90°	3/4	3/16	1/2	2-1/4	3	\$185.	\$197.
D90-1.0	90°	1.00	1/4	1/2	2-1/2	5	\$195.	\$211.
D90-1.25	90°	1.25	5/16	5/8	2-3/4	5	\$255.	\$275.
D90-1.5	90°	1.50	7/16	3/4	3-1/4	6	\$310.	\$335.
D90-1.75	90°	1.75	1/2	3/4	3-3/4	6	\$350.	\$381.
D90-2.0	90°	2.00	9/16	1.0	4	6	\$380.	\$476.
D90-2.5	90°	2.50	3/4	1.0	4-1/2	6	\$440.	\$552.

N = number of flutes

Phone 916 408-2442 FAX 916 408-0740

Toll free phone 866 440-8665



A. B. TOOLS, INC.
1051 Aviation Blvd.
Lincoln, CA, 95648-9312

If any product is not satisfactory
we will modify, replace or refund.

www.abtoolsinc.com
E-Mail: mail@abtoolsinc.com

The Dexi-Dovetail Short Inserts

.390 with Di60 inserts
Cut Depths 60°

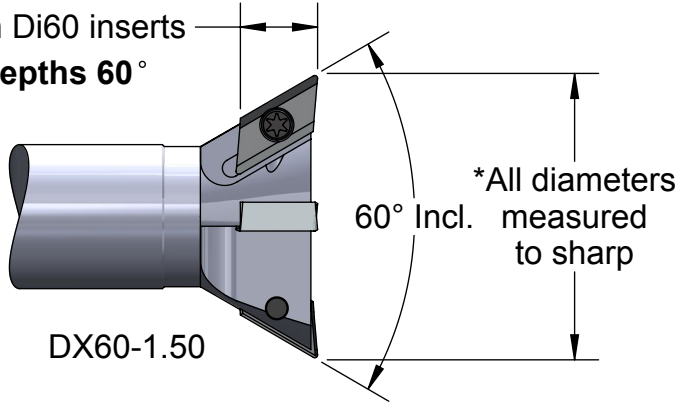

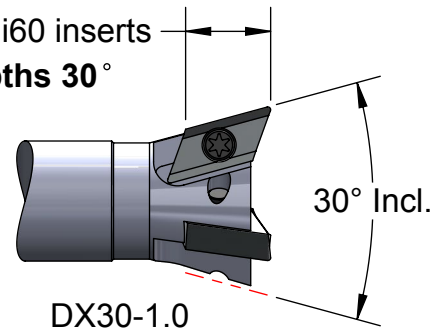

.447 with Di60 inserts
Cut Depths 30°

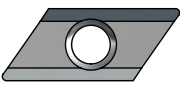

Cutter Number	*Dia.	Cut Depth	Incl. Angle	Shank & Overall	Flutes	Price
DX10-1.25	1-1/4	.440	10°	3/4 X 3.5	4	\$205.
DX20-1.0	1.0	.430	20°	3/4 X 3.5	3	\$185.
DX20-1.25	1-1/4	.430	20°	3/4 X 3.25	3	\$195.
DX20-1.50	1-1/2	.430	20°	3/4 x 3.25	4	\$215.
DX30-1.0	1.0	.420	30°	5/8 X 3.5	3	\$195.
DX30-1.25	1-1/4	.420	30°	3/4 X 3.5	3	\$195.
DX40-1.25	1-1/4	.410	40°	3/4 X 3.5	3	\$195.
DX45-1.25	1-1/4	.405	45°	3/4 X 3.25	3	\$195.
DX50-1.25	1-1/4	.400	50°	3/4 X 3.25	3	\$195.
DX60-1.25	1-1/4	.390	60°	1/2 X 3.0	3	\$195.
DX60-1.38	1-3/8	.390	60°	5/8 X 3.5	3	\$205.
DX60-1.50	1-1/2	.390	60°	3/4 X 3.5	4	\$230.
DX60-8	1-1/4	.390	60°	1-1/4 X 8.0	3	\$275.

Short Insert 	Insert Number	Radius	Price	
			No-Coat	AlTiN
	Di60-0078	.0078		
	Di60-1	.015	\$10.25	\$13.00
	Di60-2	.030		

Screw & Key 	Number	Price
	DX-3MM	\$2.00
	T8	\$5.50

We use all these cutters in production, milling (38Rc) 4340 at 1100 to 1800 RPM and .001 to .002 IPT.

Phone 916 408-2442 FAX 916 408-0740

Toll free phone 866 440-8665



A. B. TOOLS, INC.
1051 Aviation Blvd.
Lincoln, CA, 95648-9312

If any product is not satisfactory
we will modify, replace or refund.

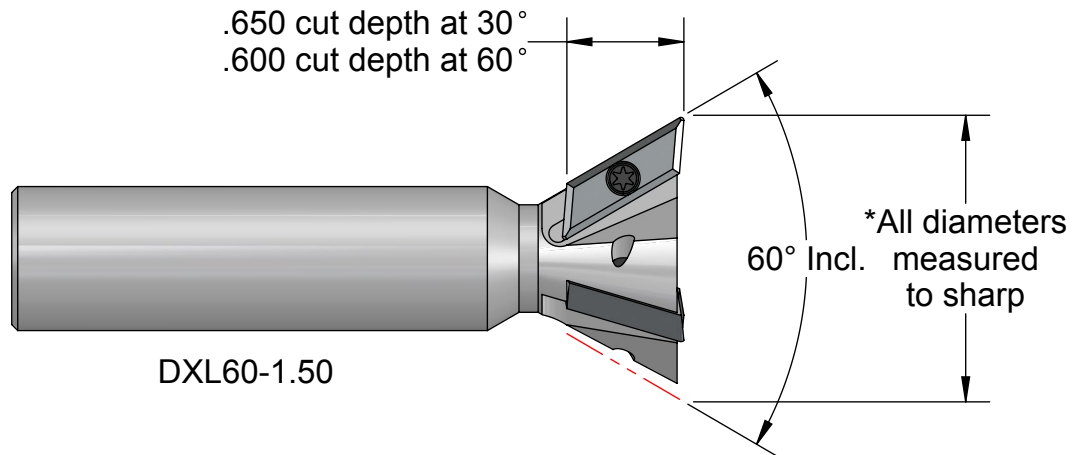

www.abtoolsinc.com
E-Mail: mail@abtoolsinc.com

The Dexi-Dovetail Long Inserts



Number	*Dia.	Cut Depth	Incl. Angle	Shank & Overall	Flutes	Price
DXL20-1.25	1-1/4	.650	20°	3/4 X 3.5	3	\$245.
DXL30-1.25	1-1/4	.640	30°	3/4 X 3.5	3	\$245.
DXL30-1.312	1-5/16	.640	30°	3/4 X 3.5	3	\$250.
DXL30-1.37	1-3/8	.640	30°	3/4 X 3.5	3	\$255.
DXL30-2.0	2.0	.640	30°	1 X 3.88	5	\$375.
DXL40-1.50	1-1/2	.650	40°	3/4 X 3.5	3	\$265.
DXL50-1.50	1-1/2	.620	50°	3/4 X 3.5	3	\$265.
DXL50-2.0	2.0	.620	50°	1 X 4.0	4	\$355.
DXL60-1.50	1-1/2	.600	60°	3/4 X 3.5	3	\$265.
DXL60-1.62	1-5/8	.600	60°	3/4 X 3.5	3	\$280.
DXL60-2.0	2.0	.600	60°	1 X 3.88	4	\$375.
DXL60-3.0	3.0	.600	60°	1-1/4 X 4.5	6	\$490.

Long Insert 	Insert Number	Radius	Price	
			No-Coat	AlTiN
	Di60L-1	.015		
	Di60L-2	.030	\$12.50	\$15.50
	Di60L-3	.046		

Screw & Key	Number	Price
	DX-3MM	\$2.00
	T8	\$5.50

*We use all these cutters in production, milling (38Rc) 4340
at 1100 to 1800 RPM and .001 to .002 IPT.*

Phone 916 408-2442 FAX 916 408-0740

Toll free phone 866 440-8665



A. B. TOOLS, INC.
1051 Aviation Blvd.
Lincoln, CA, 95648-9312

If any product is not satisfactory
we will modify, replace or refund.

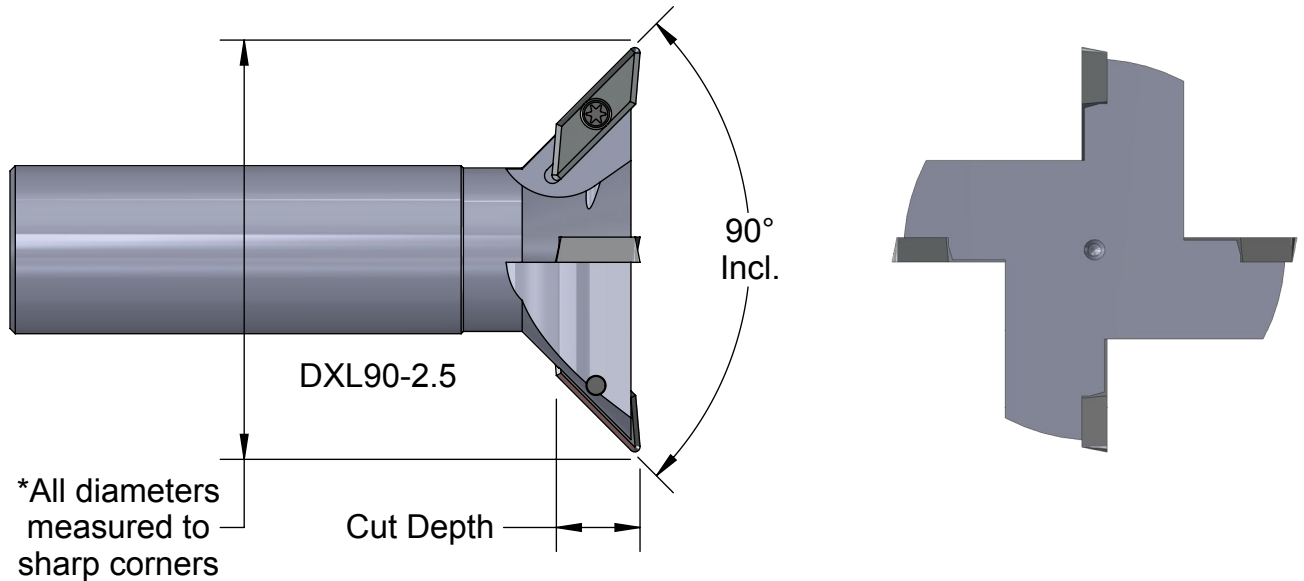

www.abtoolsinc.com
E-Mail: mail@abtoolsinc.com

70° to 90° Dexi-Dovetail Original Width Inserts

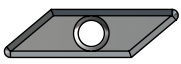

Number	*Dia.	Cut Depth	Incl. Angle	Shank & OAL	Flutes	Price
DXL70-1.75	1.750	.560	70°	3/4 X 3.75	3	\$345.
DXL70-2.0	2.000	.560	70°	1 X 3.75	3	\$355.
DXL75-2.0	2.000	.550	75°	1 X 3.75	3	\$355.
DXL80-2.0	2.000	.530	80°	1 X 3.75	3	\$355.
DXL90-2.0	2.000	.490	90°	3/4 X 3.75	3	\$355.
DXL90-2.5	2.500	.490	90°	1 X 3.75	4	\$440.
DXL90-3.0	3.000	.490	90°	1 X 3.75	5	\$505.

Original Long Insert 	Insert Number	Radius	Price	
			No-Coat	AlTiN
	Di90L-1	.015		
	Di90L-2	.030	\$12.50	\$15.00
	Di90L-3	.046		

Screw & Key	Number	Price
	DX-3MM	\$2.00
	T8	\$5.50



Phone 916 408-2442 FAX 916 408-0740

A. B. TOOLS, INC.
1051 Aviation Blvd.
Lincoln, CA, 95648-9312

If any product is not satisfactory
we will modify, replace or refund.

Toll free phone 866 440-8665

www.abtoolsinc.com
E-Mail: mail@abtoolsinc.com

NEW !!! 70° to 90° Dexi-Dovetails wider, stronger inserts

NEW !!!

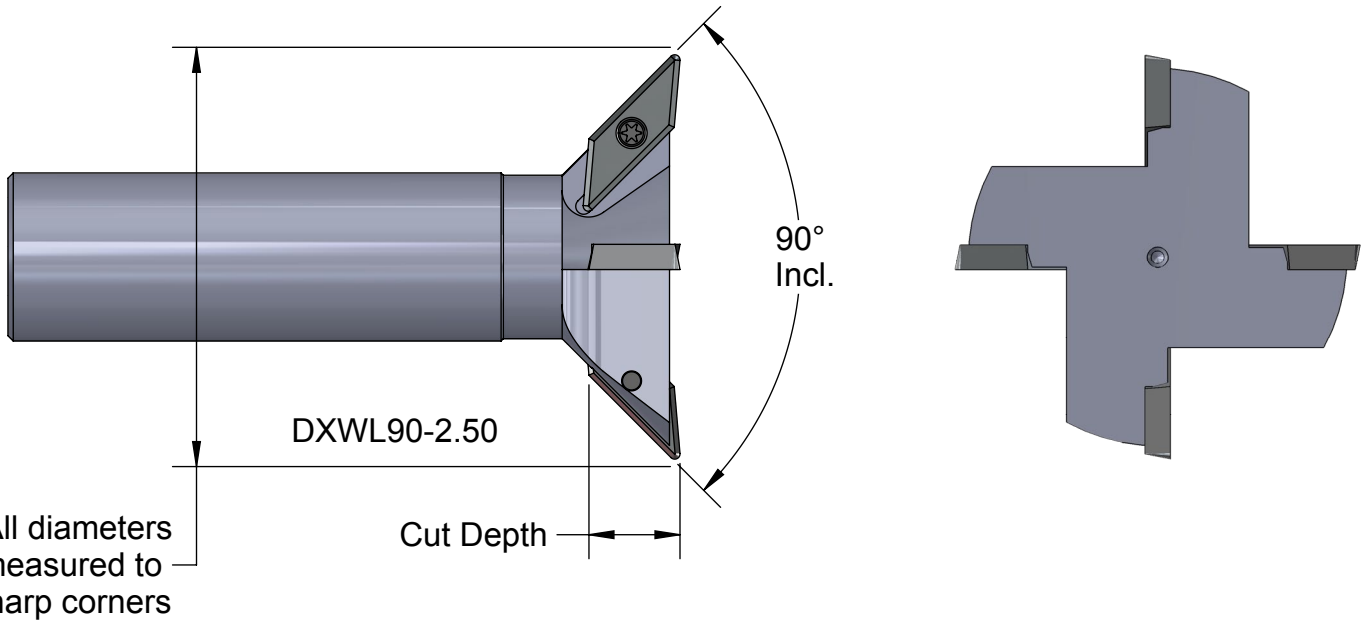

Number	*Dia.	Cut Depth	Incl. Angle	Shank & OAL	Flutes	Price
DXWL70-2.0	2.000	.560	70°	1 X 4	3	\$370.
DXWL80-2.25	2.250	.530	80°	1 X 4	3	\$405.
DXWL90-2.25	2.250	.490	90°	1 X 4	3	\$405.
DXWL90-2.50	2.500	.490	90°	1 X 4	4	\$460.
DXWL90-3.0	3.000	.490	90°	1 X 4	5	\$515.

Wide Insert				
	Insert Number	Radius	Price	
			No-Coat	AlTiN
	Di90WL-1	.015	\$13.75	\$16.25
Di90WL-2	.030			

Screw & Key	Number	Price
	DX-3MM	\$2.00
	T8	\$5.50



Phone 916 408-2442 FAX 916 408-0740

A. B. TOOLS, INC.
1051 Aviation Blvd.
Lincoln, CA, 95648-9312

If any product is not satisfactory
we will modify, replace or refund.

Toll free phone 866 440-8665

www.abtoolsinc.com
E-Mail: mail@abtoolsinc.com

Positive Rake Chamfer-Hogs

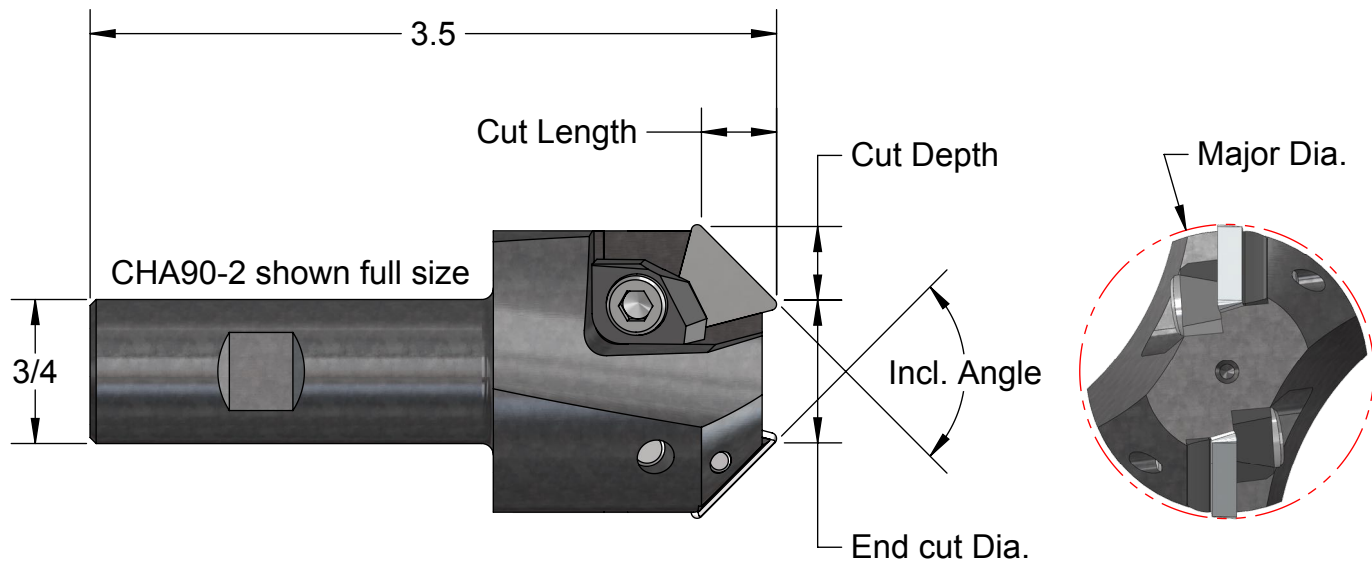

All Positive Chamfer-Hogs use
Insert TPU322 and Shim SM41
For Ferrous or Non-Ferrous

Number	Included Angle	No. of Flutes	End Dia.	Major Dia.	Cut Lgth.	Cut Depth	Clamp No.	Price Incl. Inserts
CHA90-2	90°	2	3/4	1.5	.37	.37	CL2	\$295.
CHA120-2	120°	2	5/8	1.6	.19	.42	CL2	\$295.
CHA60-3P	60°	3	1.1	1.6	.42	.19	CL5	\$385.
CHA150-2	150°	2	.47	1.56	.14	.52	CL2	\$295.

Insert	Price	Clamps	Price	Shims	Price	Screws at no charge with each purchase of Clamps & Shims. Ind. Standard 10-32 & 1/4-20 Socket Head, and 5-40 Flat Head.
TPU322 C5	\$11.	CL2	\$15.	SM41 Modified	\$15.	
		CL5	\$20.			



Phone 916 408-2442 FAX 916 408-0740

A. B. TOOLS, INC.
1051 Aviation Blvd.
Lincoln, CA, 95648-9312

If any product is not satisfactory
we will modify, replace or refund.

Toll free phone 866 440-8665

www.abtoolsinc.com
E-Mail: mail@abtoolsinc.com

Negative Rake Chamfer-Hogs (Ferrous Only)

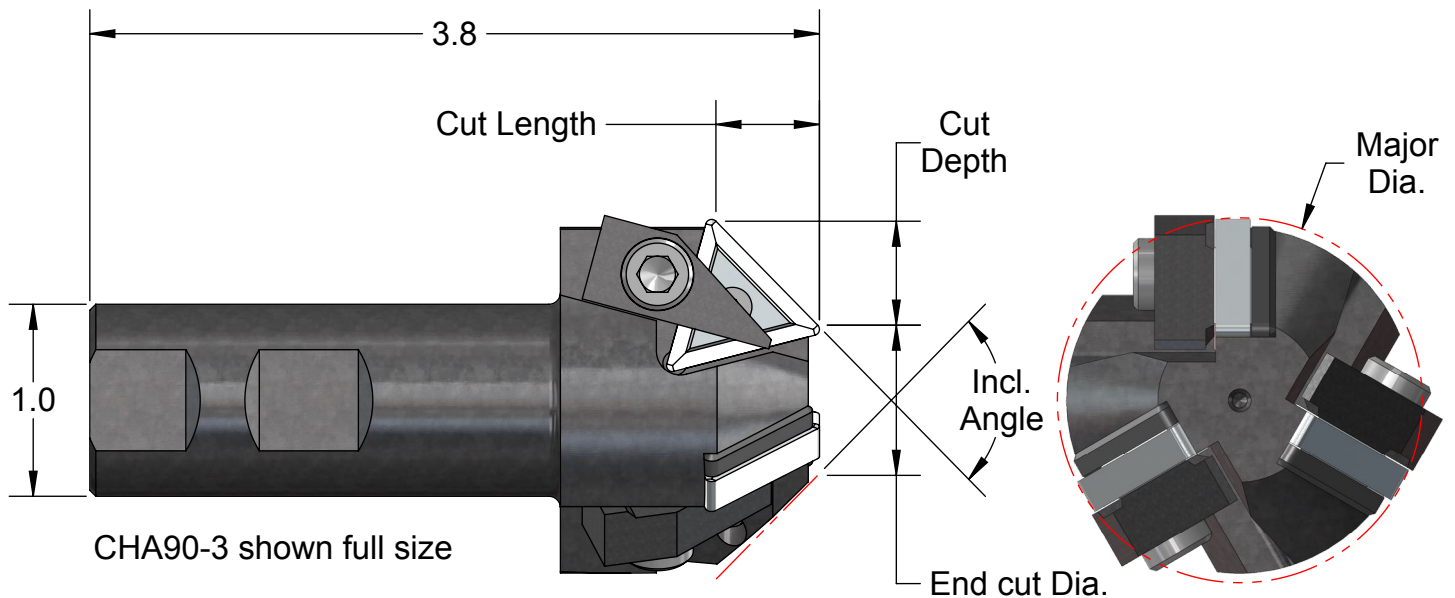

Number	Included Angle	No. of Flutes	End Dia.	Major Dia.	Cut Lgth.	Cut Depth	Clamp No.	Price Incl. Inserts
CHA30-3	30°	3	1.75	2.16	.73	.25	CL5	\$435.
CHA60-3N	60°	3	1.40	1.60	.65	.45	CL5	\$435.
CHA70-3	70°	3	1.25	2.14	.62	.44	CL5	\$435.
CHA82-3	82°	3	1.0	2.02	.57	.50	CL5	\$435.
CHA90-3	90°	3	.75	1.90	.52	.52	CL5	\$435.
CHA90-4	90°	4	1.76	2.85	.52	.52	CL5	\$495.
CHA100-3	100°	3	.82	1.99	.49	.58	CL5	\$435.
CHA110-3	110°	3	.75	2.02	.43	.62	CL5	\$435.
CHA120-3	120°	3	.75	2.10	.29	.62	CL5	\$435.
CHA130-3	130°	3	.77	2.16	.32	.67	CL5	\$435.
CHA140-3	140°	3	.75	2.20	.25	.70	CL5	\$435.

Insert	Price	Clamp	Price	Shim	Price	Screws at no charge with each purchase of Clamps & Shims. Ind. Standard 10-32 & 1/4-20 Socket Head and 5-40 Flat Head.
TNMG432 C5	\$16.	CL5	\$20.	SM26 Ind. Std.	\$10.	



Phone 916 408-2442 FAX 916 408-0740

A. B. TOOLS, INC.
1051 Aviation Blvd.
Lincoln, CA, 95648-9312

If any product is not satisfactory
we will modify, replace or refund.

Toll free phone 866 440-8665

www.abtoolsinc.com
E-Mail: mail@abtoolsinc.com

The Single Flute Chamfer Hogs

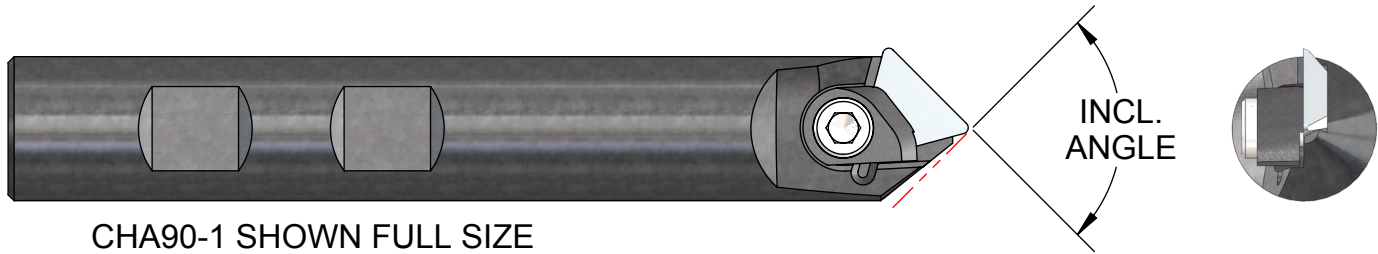

CHA90-1 SHOWN FULL SIZE

This cutter was developed in 1982 for spot drilling and chamfer milling small slots in non-ferrous part materials. If used prior to drilling in non-ferrous materials it performs well. If used as a countersink after the hole is drilled it is chatter prone.

It is not for use as a rotating cutter in ferrous materials since the (25°) relief angle is too weak. However, in the more rigid lathe environment it can be used successfully to spot drill holes in ferrous materials. We spot drill our Accu-Holds (4340) in CNC lathes at 900 RPM and .0005 IPR, with tool life of 200 holes per insert corner.

It should never be used in a drill press.

All five cutters have 3/4 shanks and are 5" overall.

All Single Flute Chamfer-Hogs, including inserts, are **\$190.** ea.

Number	Included Angle	Maximum Chamfer Diameter	Insert	Clamp	Insert Prices	
CHA90-1	90°	.800	TFG32-90	CL-4	TFG32-90	\$12.50
CHA82-1	82°	.730	TFG32-90	CL-4	TFG32-90T (TiN Coated)	\$14.75
CHA100-1	100°	.940	TFG32-90	CL-4	TD6P-120	\$14.00
CHA120-1	120°	1.00	TD6P-120	5-40		
CHA60-1*	60°	1.00	TFG32-90	CL-4		

* Note: CHA60-1 is **not** center cut; it has .200 end cut diameter.

The CL-4 Clamps are **\$15.** each, includes screw.

The 10-32 Socket Head Cap Screw is Industry Standard.

TFG-322 and TD-6P are Industry Standard Inserts modified with a secondary facet near the point to prevent "heeling".



Phone 916 408-2442 FAX 916 408-0740

A. B. TOOLS, INC.
1051 Aviation Blvd.
Lincoln, CA, 95648-9312

If any product is not satisfactory
we will modify, replace or refund.

Toll free phone 866 440-8665

www.abtoolsinc.com
E-Mail: mail@abtoolsinc.com

Spot-Dex Tools (for all part materials)

SD-90T3 shown here

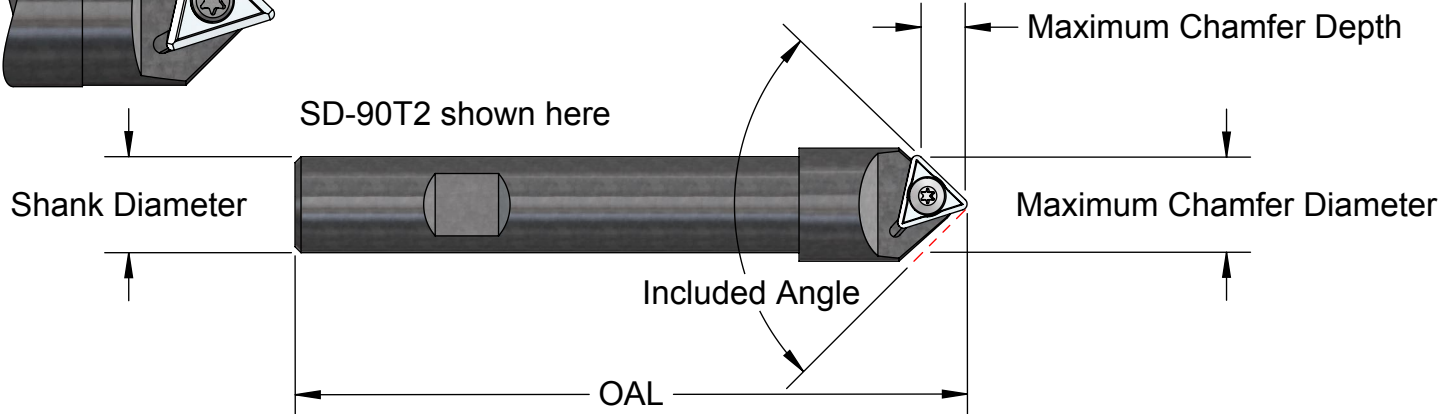
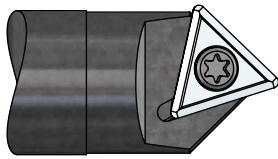

SD-60D3 shown here

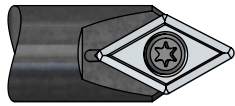

SD-60D2 shown here



These all use Industry Standard inserts with secondary clearance facets ground to avoid dragging on the small cut diameters.

We've spot drilled to .190 depth with the SD-60D2 in mild steel at 4000 RPM and 1 IPM, and milled grooves in X-Y at 10 IPM.

Number	Included Angle	Max Chamfer Dia.	Max Chamfer Depth	*Insert No. (modified)	Screw Size	Shank and OAL	Price including Wrench & Screw
SD-60D2	60°	.310	.240	DPMT-21.51	2.5MM	1/2 X 3.5	\$175.
SD-60D3	60°	.480	.380	DPMT-32.52	4MM		\$195.
SD-70D2	70°	.350	.230	DPMT-21.51	2.5MM		\$175.
SD-70D3	70°	.530	.340	DPMT-32.52	4MM		\$195.
SD-82T2	82°	.530	.290	TPMT2-2	4-40	1/2 X 3.5	\$175.
SD-82T3	82°	.770	.410	TPMT322	4MM	3/4 X 5.0	\$195.
SD-90T2	90°	.570	.270	TPMT2-2	4-40	1/2 X 3.5	\$175.
SD-90T3	90°	.820	.390	TPMT322	4MM	3/4 X 5.0	\$195.
SD-100T2	100°	.610	.240	TPMT2-2	4-40	1/2 X 3.5	\$175.
SD-100T3	100°	.890	.350	TPMT322	4MM	3/4 X 5.0	\$195.
SD-120T2	120°	.680	.190	TPMT2-2	4-40	1/2 X 3.5	\$175.
SD-120T3	120°	.990	.270	TPMT322	4MM	3/4 X 5.0	\$195.

Insert Number	R. Size	Price
DPMT-21.51	.015	\$16.25
TPMT2-2	.031	\$13.50
DPMT-32.52	.031	\$17.50
TPMT322	.031	\$16.25

Screw	Price
2.5 MM	\$3.75
4-40	\$4.25
4 MM	\$4.50
4 MM	\$4.50

Wrench	Price
Torxit-7	\$5.00
Torxit-7	\$5.00
Torxit-15	\$7.50
Torxit-15	\$7.50

Phone 916 408-2442 FAX 916 408-0740

Toll free phone 866 440-8665



A. B. TOOLS, INC.
1051 Aviation Blvd.
Lincoln, CA, 95648-9312

If any product is not satisfactory we will modify, replace or refund.

www.abtoolsinc.com
E-Mail: mail@abtoolsinc.com

Are you tired of hand ground screw flats on your tool and cutter shanks?

Mill precise flats with our Weldon Flat Tools.

See page 49 for the USCTI Weldon Flat specifications

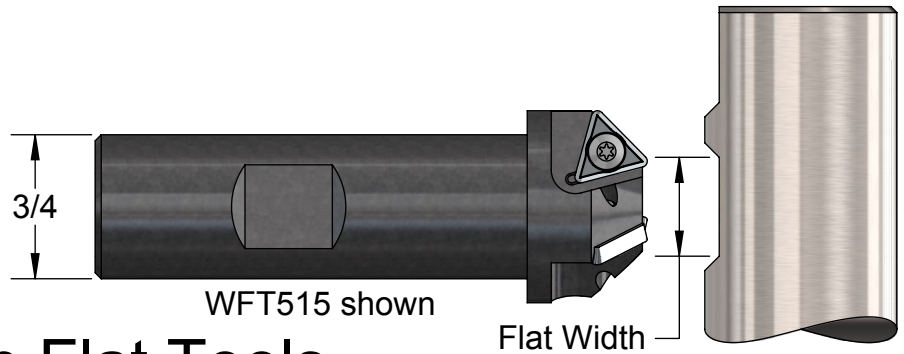

Weldon Flat Tools

Number	Flat Width	For these Shank sizes	Number of Flutes	Price
WFT280	.280	.375	1	\$185.
WFT330	.330	.500	2	\$200.
WFT400	.400	.625	2	\$215.
WFT455	.455	.750 & .875	3	\$245.
WFT515	.515	1.0, 1.25, 1.5	3	\$260.
WFT700	.700	2.0	3	\$310.

We mill Weldon Flats with the WFT515 in 4340 alloy steel hardened to Rc 46 @ 1500 RPM and .002 IPT. These cutters will also mill the shanks on standard HSS end mills which are drawn to Rc 55.

Would you prefer linear flats for easy "Z" Axis adjustment?

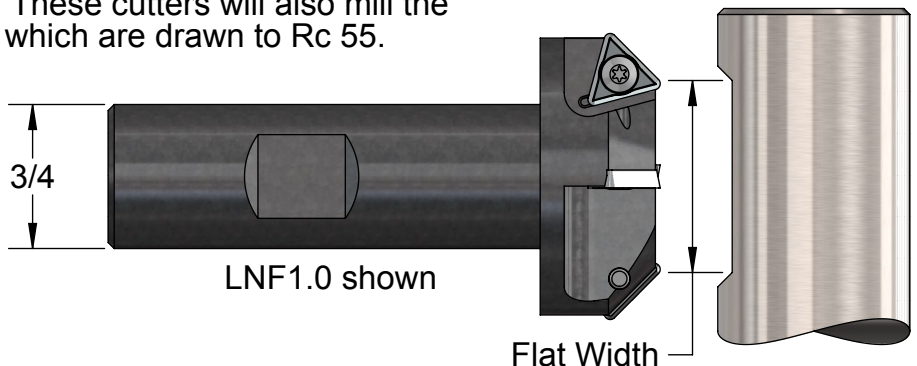

Linear Flat Tools for any Shank size

Number	Flat Width	Number of Flutes	Price
LNF750	.750	4	\$315.
LNF1.0	1.000	4	\$335.
LNF1125	1.125	4	\$365.
LNF1250	1.250	5	\$410.

Insert	Price
TPMT2-2	\$13.50

Screw	Price
SR 14-505	\$4.25

Wrench	Price
Torxit-7	\$5.00

Phone 916 408-2442 FAX 916 408-0740

Toll free phone 866 440-8665



A. B. TOOLS, INC.
1051 Aviation Blvd.
Lincoln, CA, 95648-9312

If any product is not satisfactory we will modify, replace or refund.

www.abtoolsinc.com
E-Mail: mail@abtoolsinc.com

SAW ARBORS for Carbide or HSS Saws with key drives for 5/8 and larger arbors

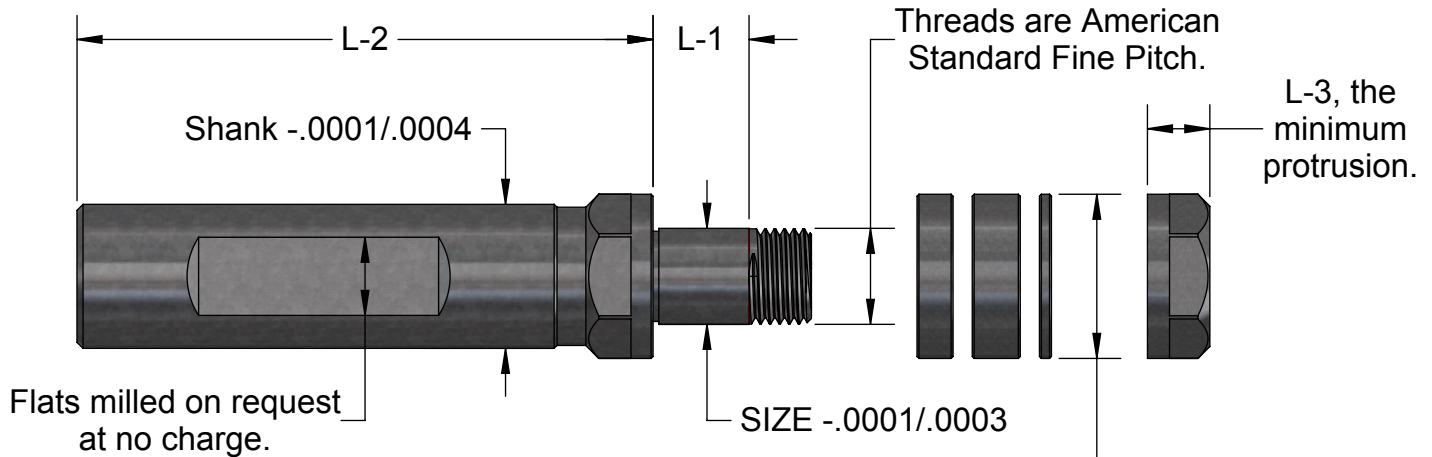

Saws thinner than .050 must not rest on the shoulder. Either on one spacer or several.

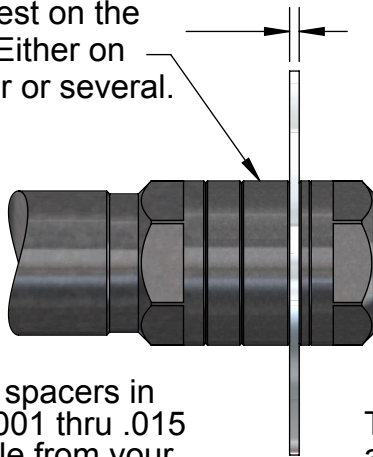

HUB ϕ , the outside diameter of the Shoulder, Hex Nut and the spacers.

Precise, for the thinnest saws.
High Torque for Keyless saws.
Rugged, with key drives.

Hardened Alloy Steel, precision ground, Black Oxide coated.

Shim Style spacers in sets from .001 thru .015 are available from your Industrial Distributor.

The spacer assortments will accommodate most saws and spacers that will fit in the L-1 Length.
*Spacers ordered with Keyed Arbors will also have keyways.

Number	Size	Shank	L-1	L-2	L-3	Hub	Spacers with each Arbor	Price
SA250	.250	.500	.350	2.13	.250	.570	.0625 .125 .1875	\$205.
SA375	.375	.625	.375	2.40	.280	.710		\$225.
SA500	.500	.750	.500	3.00	.325	.855		\$245.
SA625	.625	.875	.500	3.15	.390	1.000	.0625 .1875 .250	\$310.
SA750	.750	1.00	.500	3.40	.440	1.215		\$325.
SA875	.875	1.00	.500	3.40	.440	1.434		\$335.
SA100	1.00	1.00	.500	3.50	.440	1.480		\$375.
SA125	1.25	1.25	.500	3.50	.440	2.000		\$445.

*Sorry, unable to manufacture precise spacers thinner than .0625 in steel; suggest Robb-Jack's Solid Carbide spacers for thinner sizes.

Phone 916 408-2442 FAX 916 408-0740

Toll free phone 866 440-8665



A. B. TOOLS, INC.
1051 Aviation Blvd.
Lincoln, CA, 95648-9312

If any product is not satisfactory we will modify, replace or refund.

www.abtoolsinc.com
E-Mail: mail@abtoolsinc.com

The Accu-Hold

The MOST precise extension holder you have ever used.

Concentric within .0003; Hole size is plus .00015 and minus Zero.

Improves rigidity, concentricity, and coolant effectiveness.

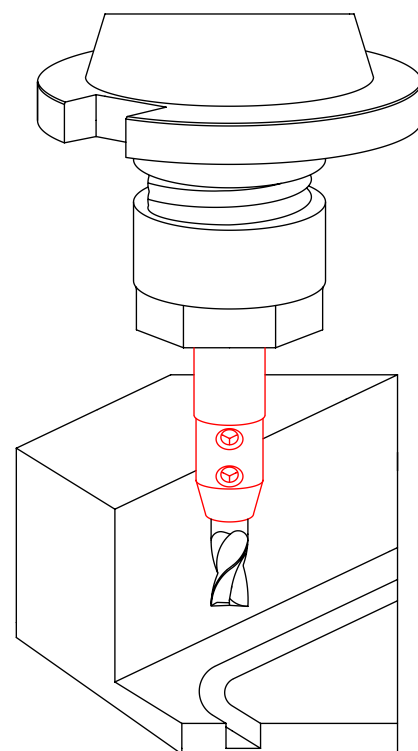
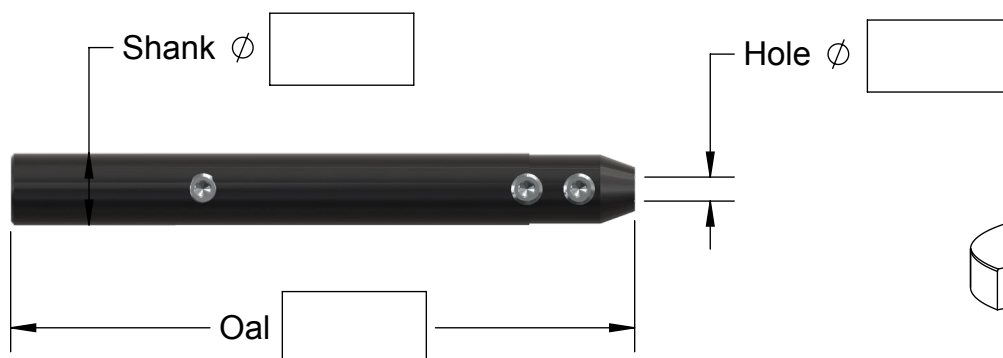

Number	Hole size Ø	Decimal Equiv.	Shank size Ø	Overall Length	Screw Size	Price
ACH3/32	3/32	.0937	3/8	2-1/4	5-40	\$165.
ACH1/8	1/8	.125	3/8	3-1/4	8-32	\$175.
ACH1/8-6	1/8	.125	3/8	6	8-32	\$250.
ACH5/32	5/32	.1562	1/2	3-1/2	8-32	\$150.
ACH3/16	3/16	.1875	1/2	3-1/2	8-32	\$150.
ACH3/16-5	3/16	.1875	1/2	5	8-32	\$185.
ACH1/4	1/4	.250	5/8	4-1/4	10-32	\$160.
ACH1/4-6	1/4	.250	5/8	6	10-32	\$190.
ACH5/16	5/16	.3125	3/4	4-1/2	1/4-28	\$175.
ACH3/8	3/8	.375	3/4	4-1/2	5/16-24	\$185.
ACH3/8-6	3/8	.375	3/4	6	5/16-24	\$215.
ACH7/16	7/16	.4375	3/4	4-1/2	5/16-24	\$200.
ACH1/2*	1/2	.500	3/4	4-3/4	3/8-24	\$235.
ACH1/2-1	1/2	.500	1	4-3/4	3/8-24	\$250.
ACH1/2-6	1/2	.500	1	6	3/8-24	\$275.
ACH9/16	9/16	.5625	1	5-1/4	3/8-24	\$275.
ACH5/8	5/8	.625	1	5-1/2	3/8-24	\$275.
ACH3/4**	3/4	.750	1	5-1/4	7/16-20	\$310.
ACH3/4-1.25	3/4	.750	1-1/4	6	7/16-20	\$315.
ACH1.0**	1	1.000	1	5-1/2	7/16-20	\$445.

*The ACH1/2 has a 1 Dia. x 1.5 long head.

**The ACH3/4 and ACH1.0 have a 1-1/4 Dia. x 2-1/4 long head and the holes are only 2" deep.



Phone 916 408-2442 FAX 916 408-0740

A. B. TOOLS, INC.
1051 Aviation Blvd.
Lincoln, CA, 95648-9312

If any product is not satisfactory
we will modify, replace or refund.

Toll free phone 866 440-8665

www.abtoolsinc.com
E-Mail: mail@abtoolsinc.com

The Metric Accu-Hold

The MOST precise extension holder you have ever used.

Concentric within .0003; Hole size is plus .00015 and minus Zero.

Improves rigidity, concentricity, and coolant effectiveness.

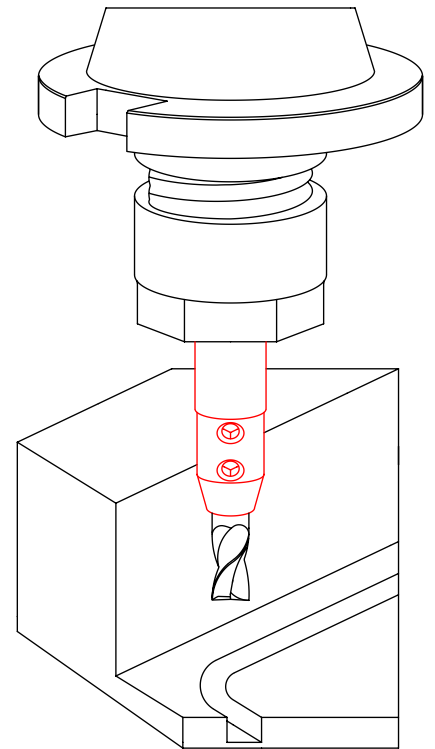
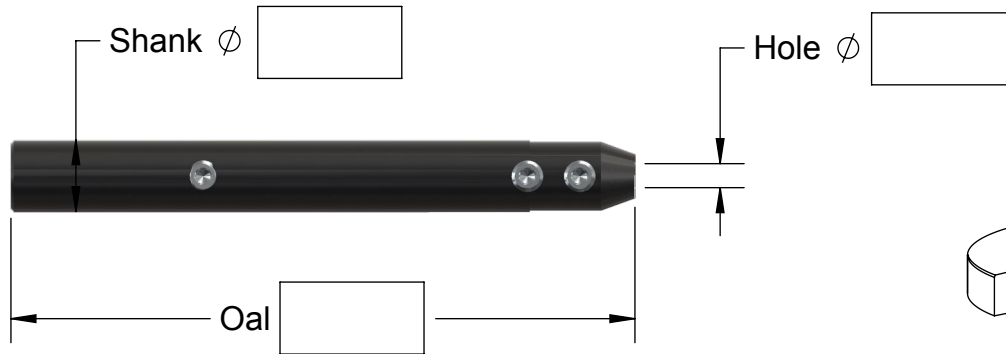

Number	Hole size Ø	Decimal Equiv.	Shank size Ø	Overall Length	Screw Size	Price
ACH3MM	3MM	.1181	3/8	3-1/4	6-32	\$175.
ACH4MM	4MM	.1575	1/2	3-1/2	8-32	\$160.
ACH5MM	5MM	.1968	1/2	3-1/2	10-32	\$160.
ACH6MM	6MM	.2362	5/8	4-1/4	10-32	\$165.
ACH7MM	7MM	.2756	5/8	4-1/4	10-32	\$215.
ACH8MM	8MM	.3149	3/4	4-1/2	1/4-28	\$175.
ACH9MM	9MM	.3543	3/4	4-1/2	5/16-24	\$225.
ACH10MM	10MM	.3937	3/4	4-1/2	5/16-24	\$205.
ACH11MM	11MM	.4331	3/4	4-1/2	5/16-24	\$245.
ACH12MM*	12MM	.4724	3/4	4-3/4	3/8-24	\$230.
ACH12MM-1	12MM	.4724	1	4-3/4	3/8-24	\$240.
ACH13MM	13MM	.5118	1	4-3/4	3/8-24	\$260.
ACH14MM	14MM	.5512	1	5-1/2	3/8-24	\$260.
ACH15MM	15MM	.5905	1	5-1/2	3/8-24	\$285.
ACH16MM	16MM	.6299	1	5-1/2	3/8-24	\$280.
ACH18MM**	18MM	.7086	1	5-1/4	7/16-20	\$295.
ACH20MM-1	20MM	.7874	1	6	7/16-20	\$315.
ACH20MM	20MM	.7874	1-1/4	6	7/16-20	\$315.
ACH25MM**	25MM	.9842	1	6-1/2	7/16-20	\$445.

*The ACH12MM has a 1" Dia. x 1.5" long head.

**The ACH18MM and ACH25MM have a 1-1/4" Dia. x 2-1/4" long head and the holes are only 2" deep.



Phone 916 408-2442 FAX 916 408-0740

A. B. TOOLS, INC.
1051 Aviation Blvd.
Lincoln, CA, 95648-9312

If any product is not satisfactory
we will modify, replace or refund.

Toll free phone 866 440-8665

www.abtoolsinc.com
E-Mail: mail@abtoolsinc.com

Speed/Feed Formulas, and Shank Flat Data

SFM = RPM X .262 X Tool Diameter
 RPM = SFM X 3.82 / Tool Diameter
 IPM = RPM X IPT X Number of Flutes

IPT = IPM / (RPM X Number of Flutes)
 CIM = Width X Depth X IPM
 HP = KW X 1.341

Comparative Estimates of CIM per HP for various part materials, (using carbide);
 Cold Rolled Steel (1018)..... 1 CIM per HP
 Aluminum, Magnesium, Plastics, Graphite..... 4 to 6 CIM per HP
 Cast Iron, 303..... .7 to .8 CIM per HP
 Tool Steel, Alloy Steel, 304-316, 17-4PH, 6AL-4V.. .4 to .6 CIM per HP
 Inconel and other High Temperature Alloys..... .2 to .4 CIM per HP

Suggested SFM and IPT are shown in *Italics* on each page with each Cutter Style.

Shank	Flat	"Y"	"X"	Depth	S/L	W/N
3/8	.280		.781	.050	1.56	1.0
1/2	.330		.890	.065	1.78	1.06
5/8	.400		.953	.070	1.90	1.19
3/4	.455		1.015	.075	2.03	1.25
7/8	.455	.50	1.015	.075	2.03	1.25
1.0	.515	.50	1.140	.075	2.28	1.44
1-1/4	.515	.50	1.140	.095	2.28	1.44

Weldon & Whistle-Notch Flat Specifications

Note: We suggest using the depths shown as minimums to avoid screw damage.

Accu-Bores

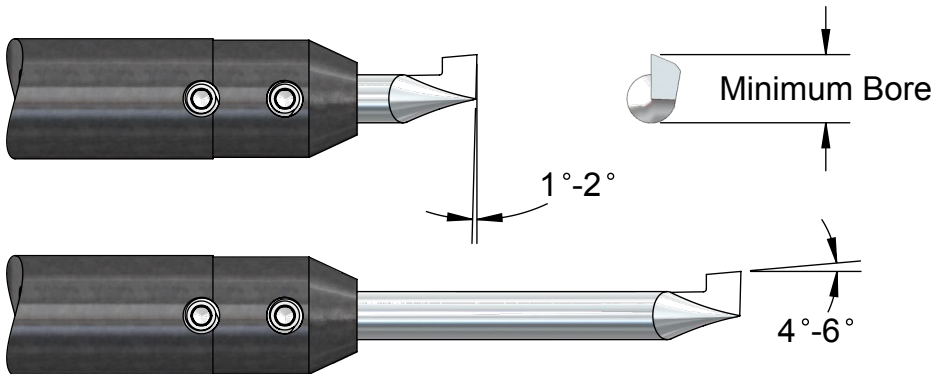

Solid Carbide boring tools. (Micro-grain Heads silver soldered on Solid Carbide Shanks). They can be set to any bore depth with maximum rigidity.

Not intended for boring head use.

Number	Min. Bore	Shank	OAL	Price	
				No-Coat	AlTiN
ACB-130	.130	3/32	2.06	\$50.	\$53.
ACB-180	.180	1/8	2.12	\$55.	\$59.
ACB-245	.245	3/16	2.62	\$60.	\$64.
ACB-355	.355	1/4	3.18	\$65.	\$71.

Number	Min. Bore	Shank	OAL	Price	
				No-Coat	AlTiN
ACB-480	.480	3/8	3.68	\$75.	\$84.
ACB-630	.630	1/2	4.18	\$105.	\$118.
ACB630-6	.630	1/2	6.18	\$125.	\$142.

Phone 916 408-2442 FAX 916 408-0740

Toll free phone 866 440-8665



A. B. TOOLS, INC.
 1051 Aviation Blvd.
 Lincoln, CA, 95648-9312

If any product is not satisfactory we will modify, replace or refund.

www.abtoolsinc.com
 E-Mail: mail@abtoolsinc.com

Aluminum Milling Tests

Faster CIM metal removal rates in aluminum depend more on IPM feed rates, horsepower and the cutter geometry than RPM.

You'll get higher CIM with smaller cutters, (assuming you're rough milling with cutters about one inch in diameter and larger). On tests 5, 6 and 8, with full diameter cuts, the one inch gets 46 CIM, the 1-1/4 gets 42 CIM and the two inch gets 37 CIM.

You'll get higher CIM with a cut width that is about 3/4 of the cutter diameter than with a full diameter cut width, (a long accepted machinist's rule).

Compare Tests 1 versus 3 and 6 versus 7. You can get the same CIM with fewer flutes, plus reduced insert costs; see Test 8.

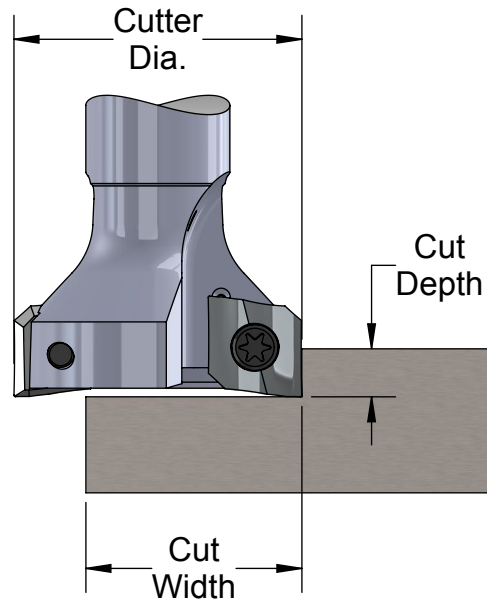

See inside back cover for SH750 along with back cover for all shank style Shear-Hogs.

Test No.	Cutter	Cutter Dia.	RPM	Cut Width	Cut Depth	IPM Feed	No. Flutes	IPT Chip	CIM
1.	SH750	.750	7500	.750	.375	150	1	.020	42
2.	*below	.750	7500	.750	.375	130	2	.008	36
3.	SH750	.750	7500	.600	.250	315	1	.042	46
4.	*below	.750	7500	.600	.250	275	2	.018	41
5.	SH100	1.0	6500	1.0	.125	370	1	.057	46
6.	SH125	1.25	6500	1.25	.125	275	2	.027	42
7.	SH125	1.25	6500	1.0	.250	375	2	.037	47
8.	SH200	2.0	6500	2.0	.250	75	2 & 3	.006/.004	37

* A major brand solid carbide, 2 flute end mill, with High Rake for aluminum.

All tests were run on a recent model Haas VF1 based on the highest Inches Per Minute possible with the load meter showing 100%. Haas estimates 7.5 actual spindle HP at 6500 RPM.



Phone 916 408-2442 FAX 916 408-0740

A. B. TOOLS, INC.
1051 Aviation Blvd.
Lincoln, CA, 95648-9312

If any product is not satisfactory
we will modify, replace or refund.

Toll free phone 866 440-8665

www.abtoolsinc.com
E-Mail: mail@abtoolsinc.com

The Aluma-Hogs

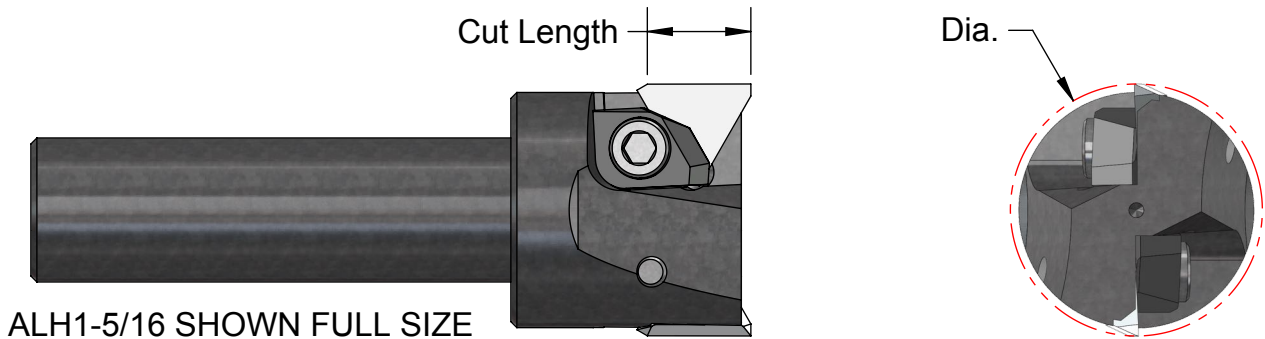

ALH1-5/16 SHOWN FULL SIZE

We started making ALUMA-HOGS in 1982. In 1997 we introduced the SHEAR-HOG; see back cover. With its high shear inserts, and no top clamps, the SHEAR-HOG outperforms the ALUMA-HOGS by 50% in Metal Removal rates. We will stock Aluma-Hogs, inserts, and parts as long as needed.

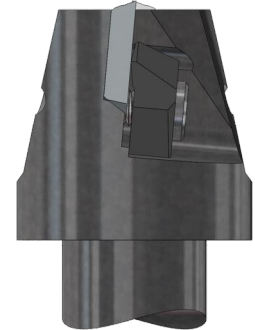

NUMBER	Dia.	Shank Dia.	OAL	Cut Length	Insert & Qty.	Clamp	Shim	Price Incl. Inserts
ALH1A	1.0	3/4	3.75	1/4	TEG2.522 (2)	CL1		\$195.
ALH1B	1.0	1.0	3.75	1/4	TEG2.522 (2)	CL1		\$195.
ALH1-5/16	1.312	3/4	3.75	1/2	TEG32MF (2)	CL2		\$245.
ALH1-7/8A	1.875	3/4	3.87	3/4	TEG42MF (2)	CL3		\$260.
ALH1-7/8B	1.875	1.0	4.12	3/4	TEG42MF (2)	CL3		\$260.
ALH2	2.0	1.0	4.12	3/4	TEG42MF (2)	CL3		\$295.
ALH3S	3.0	1.0	4.12	3/4	TEG42MF (3)	CL3	SM37	\$380.
ALH4S	4.0	1.0	4.25	3/4	TEG42MF (4)	CL3	SM37	\$495.

Inserts/Hardware	Relief Angle	Price
TEG2.522 (.031 R)	20°	\$11.00
TEG2.52MF (Mill Flat)	20°	\$12.50
TFG322 (.031 R)	25°	\$11.00
TFG32MF (Mill Flat)	25°	\$12.50
TEG422 (.031 R)	20°	\$13.25
TEG42MF (Mill Flat)	20°	\$15.50
CL1 or CL2 Clamp		\$15.00
CL3 Clamp		\$20.00
SM37 Shim, Modified		\$15.00

*Suggested Starting Data:
Non-Ferrous ONLY
500/10,000 SFM; .002/.010 IPT*

See back cover, inside back cover and page 50 for information on the SHEAR-HOG, which will rough mill Aluminum at 6 CIM per HP.

Screws included with any Clamp/Shim orders.

Phone 916 408-2442 FAX 916 408-0740

Toll free phone 866 440-8665



A. B. TOOLS, INC.
1051 Aviation Blvd.
Lincoln, CA, 95648-9312

If any product is not satisfactory we will modify, replace or refund.

www.abtoolsinc.com
E-Mail: mail@abtoolsinc.com

Shell Shear-Hogs®

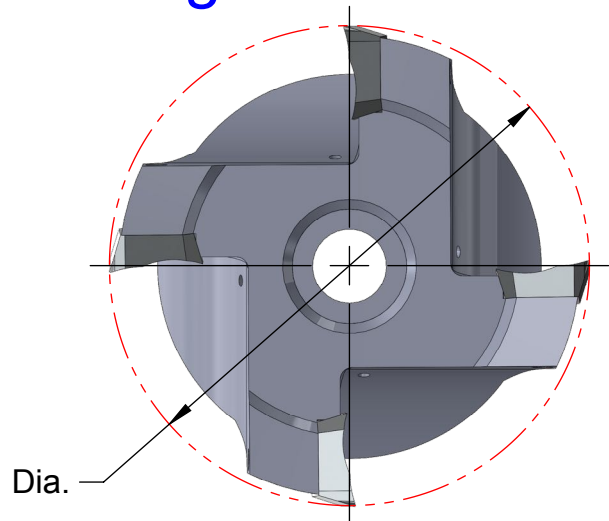
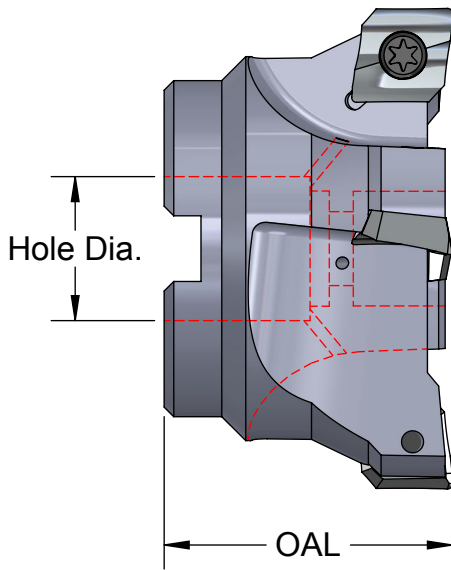

All cutter prices include inserts, insert screws, coolant screw and wrench

Number	Dia.	Hole Dia.	OAL	No. of Flutes	Price Incl. Inserts	Coolant Screws	
						Size	Price
SHELL 200	2.0	.500	1.25	2 or 3	\$395.	1/4-28	\$7.50
SHELL 250	2.5	.750	1.50	4	\$435.	3/8-24	\$7.50
SHELL 300	3.0	1.00	1.75	4	\$495.	1/2-20	\$8.75
SHELL 400	4.0	1.25	1.87	4	\$575.	5/8-18	\$11.00
SHELL 500	5.0	1.50	2.25	5	\$725.	3/4-16	\$12.50
SHELL 600	6.0	1.50	2.25	6	\$950.	3/4-16	\$12.50
SHELL 700	7.0	1.50	2.25	8	\$1500.	3/4-16	\$12.50

You may use Std. Socket Head screws without thru-tool coolant. Or, use our modified screws with coolant holes



Shear-Hog Inserts	Corner	Price
ADEH-431	.010 R	\$18.75 ea.
ADEH-432	.030 R	\$18.75 ea.
ADEH-434	.060 R	\$18.75 ea.
ADEH-436	.090 R	\$20.50 ea.
ADEH-438	.120 R	\$20.50 ea.
ADEH-45	.015 x 45°	\$20.50 ea.

Extra Insert Features	Add to Price
.002 Honed Edge	\$3.00
AlTiN Coat	\$4.00
DLC Coat	\$5.50
Honed Edge & AlTiN Coat	\$7.00
Insert Screws and Wrench	
3.5mm-SH (2012 and newer)	\$1.75 ea.
8-32-SH (Older than 2012)	\$1.75 ea.
T15 Wrench	\$7.50 ea.

Phone 916 408-2442 FAX 916 408-0740

Toll free phone 866 440-8665



A. B. TOOLS, INC.
1051 Aviation Blvd.
Lincoln, CA, 95648-9312

If any product is not satisfactory we will modify, replace or refund.

www.abtoolsinc.com
E-Mail: mail@abtoolsinc.com

T-Slot Shear-Hogs®

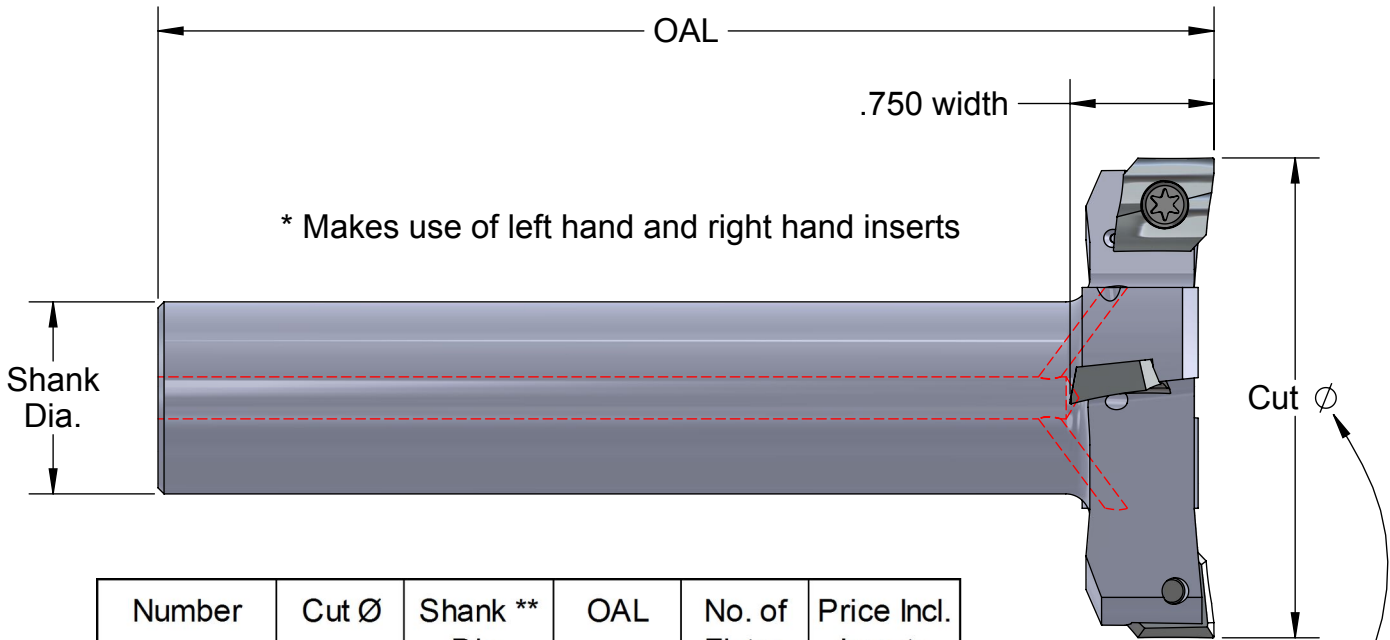

Number	Cut Ø	Shank ** Dia.	OAL	No. of Flutes	Price Incl. Inserts
TS 150	1.50	3/4	4.5	2	\$425.
TS 175	1.75	3/4	5.5	2	\$450.
TS 200	2.00	1.0	6	2	\$495.
TS 250	2.50	1.0	5.5	4	\$525.
TS 325	3.25	1-1/4	6	4	\$650.
TS 400	4.00	1-1/4	7	4	\$745.
TS 450	4.50	1-1/4	7	6	\$795.

Cutting diameters are not for finish profiling with T-Slot Shear-Hogs.

Inserts can be spun ground in T-Slot Shear-Hogs to cut straight in that tool only at an additional charge.

** We can modify shanks to smaller sizes.
Price & lead time based on specific request.



LH/RH Inserts same price

Shear-Hog Inserts	Corner	Price
ADEH-431	.010 R	\$18.75 ea.
ADEH-432	.030 R	\$18.75 ea.
ADEH-434	.060 R	\$18.75 ea.
ADEH-436	.090 R	\$20.50 ea.
ADEH-438	.120 R	\$20.50 ea.
ADEH-45	.015 x 45°	\$20.50 ea.

Extra Insert Features	Add to Price
.002 Honed Edge	\$3.00
AlTiN Coat	\$4.00
DLC Coat	\$5.50
Honed Edge & AlTiN Coat	\$7.00
Insert Screws and Wrench	
3.5mm-SH (2012 and newer)	\$1.75 ea.
8-32-SH (Older than 2012)	\$1.75 ea.
T15 Wrench	\$7.50 ea.



Phone 916 408-2442 FAX 916 408-0740

A. B. TOOLS, INC.
1051 Aviation Blvd.
Lincoln, CA, 95648-9312

If any product is not satisfactory
we will modify, replace or refund.

Toll free phone 866 440-8665

www.abtoolsinc.com
E-Mail: mail@abtoolsinc.com

Single Flute Shear-Hog®

The Shear-Hogs have no set-screw flats for possible shrink fit use or balancing. We will mill flats per request at no charge.

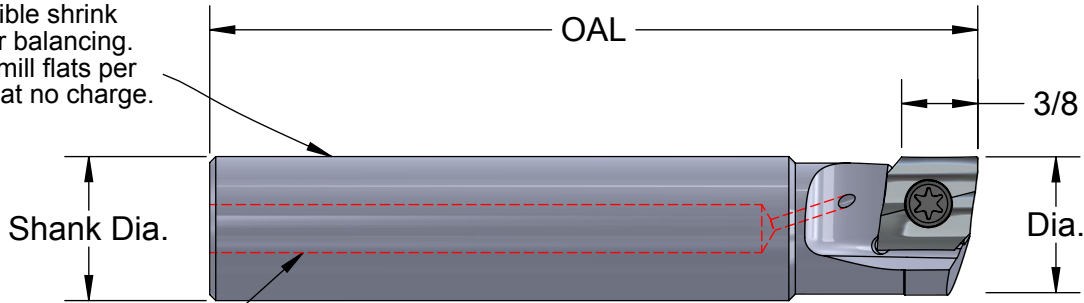

SH750 SHOWN FULL SIZE
Thru Tool Coolant

Number	Dia.	Shank Dia.	OAL	No. of Flutes	Ramp Angle	Price
SH750	.750	3/4	4.0	1	Drills in Z!	\$195.
SH750-6	.750	3/4	6.0	1	Drills in Z!	\$240.
SH750-9	.750	3/4	9.0	1	Drills in Z!	\$300.
SH787	.787 20MM	3/4	4.0	1	Drills in Z!	\$195.
SH787-6	.787 20MM	3/4	6.0	1	Drills in Z!	\$240.
SH875	.875	3/4	4.0	1	Drills in Z!	\$195.
SH875-6	.875	3/4	6.0	1	Drills in Z!	\$240.
SH984	.984 25MM	3/4	4.0	1	Drills in Z!	\$195.
SH984-6	.984 25MM	3/4	6.0	1	Drills in Z!	\$240.
SH100	1.0	3/4	4.0	1	Drills in Z!	\$195.
SH100-6	1.0	3/4	6.0	1	Drills in Z!	\$240.
SH100-9	1.0	3/4	9.0	1	Drills in Z!	\$300.

All cutter prices include Inserts, Screws, and Wrench, assembled and ready to cut.

See page 50 for recent test results on a HAAS VF1

Shear-Hog Inserts	Corner	Price
ADEH-431	.010 R	\$18.75 ea.
ADEH-432	.030 R	\$18.75 ea.
ADEH-434	.060 R	\$18.75 ea.
ADEH-436	.090 R	\$20.50 ea.
ADEH-438	.120 R	\$20.50 ea.
ADEH-45	.015 x 45°	\$20.50 ea.

Extra Insert Features	Add to Price
.002 Honed Edge	\$3.00
AlTiN Coat	\$4.00
DLC Coat	\$5.50
Honed Edge & AlTiN Coat	\$7.00
Insert Screws and Wrench	
3.5mm-SH (2012 and newer)	\$1.75 ea.
8-32-SH (Older than 2012)	\$1.75 ea.
T15 Wrench	\$7.50 ea.

Are you rough milling aluminum at 6 CIM per HP?

Phone 916 408-2442 FAX 916 408-0740

Toll free phone 866 440-8665



A. B. TOOLS, INC.
1051 Aviation Blvd.
Lincoln, CA, 95648-9312

If any product is not satisfactory we will modify, replace or refund.

www.abtoolsinc.com
E-Mail: mail@abtoolsinc.com

Multi Flute Shear-Hog®

The Shear-Hogs have no set-screw flats for possible shrink fit use or balancing. We will mill flats per request at no charge.

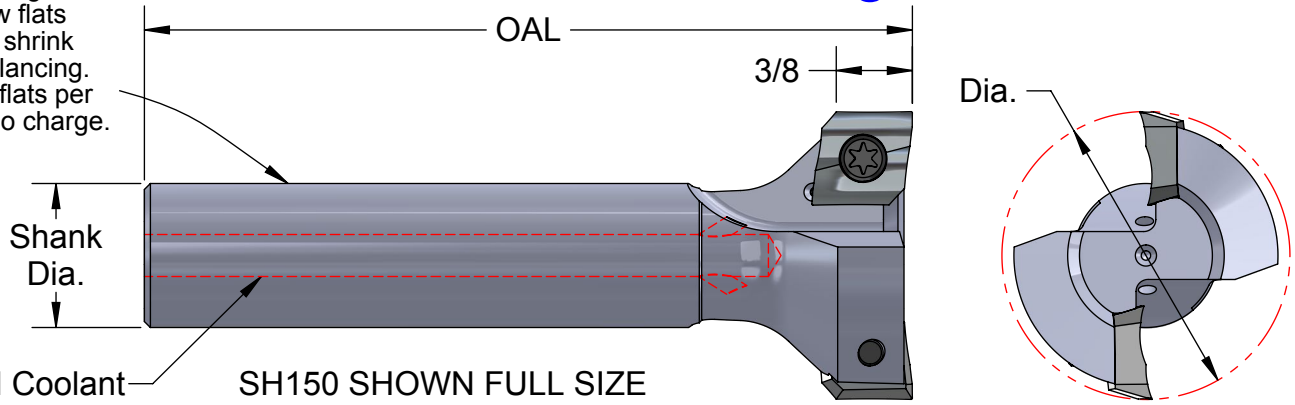

Are you rough milling aluminum at 6 CIM per HP?

Number	Dia.	Shank Dia.	OAL	No. of Flutes	Ramp Angle	Price	Shear-Hog Inserts	Corner	Price
SH125	1-1/4	3/4	4.0	2	8°	\$225.	ADEH-431	.010 R	\$18.75 ea.
SH125-1	1-1/4	1.0	4.0	2	8°	\$235.	ADEH-432	.030 R	\$18.75 ea.
SH125-6	1-1/4	1.0	6.0	2	8°	\$300.	ADEH-434	.060 R	\$18.75 ea.
SH125-9	1-1/4	1.0	9.0	2	8°	\$395.	ADEH-436	.090 R	\$20.50 ea.
SH150	1-1/2	3/4	4.0	2	5°	\$260.	ADEH-438	.120 R	\$20.50 ea.
SH150-1	1-1/2	1.0	4.5	2	5°	\$270.	ADEH-45	.015 x 45°	\$20.50 ea.
SH150-7	1-1/2	1-1/4	7.0	2	5°	\$335.	Extra Insert Features		Add to Price
SH150-8	1-1/2	1.0	8.0	2	5°	\$365.	.002 Honed Edge		\$3.00
SH200-3/4	2.0	3/4	4.5	3	4°	\$310.	AlTiN Coat		\$4.00
SH200-1	2.0	1.0	5.0	3	4°	\$310.	DLC Coat		\$5.50
SH200-7	2.0	1-1/4	7.0	3	4°	\$375.	Honed Edge & AlTiN Coat		\$7.00
SH200-9	2.0	1-1/4	9.0	3	4°	\$425.	Insert Screws and Wrench		
SH300-3/4	3.0	3/4	5.0	4	None	\$415.	3.5mm-SH (2012 and newer)		\$1.75 ea.
SH300-1	3.0	1.0	5.0	4	None	\$415.	8-32-SH (Older than 2012)		\$1.75 ea.
SH300-1.25	3.0	1-1/4	5.0	4	None	\$415.	T15 Wrench		\$7.50 ea.
SH400-1.25	4.0	1-1/4	5.0	4	None	\$550.			
SH450	4-1/2	1-1/4	5.5	5	None	\$625.			

All cutter prices include Inserts, Screws, and Wrench, assembled and ready to cut.

See page 50 for recent test results on a HAAS VF1

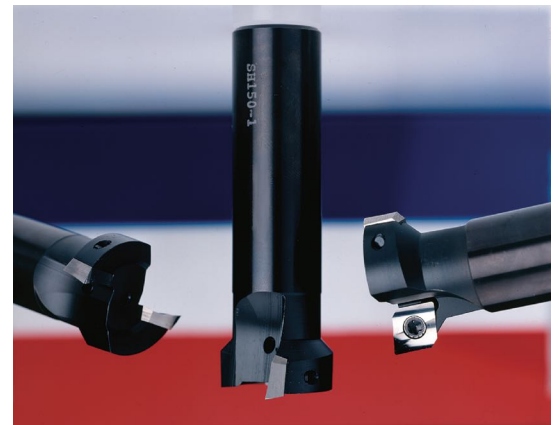

Phone 916 408-2442 FAX 916 408-0740

A. B. TOOLS, INC.
1051 Aviation Blvd.
Lincoln, CA, 95648-9312

If any product is not satisfactory we will modify, replace or refund.

Toll free phone 866 440-8665

www.abtoolsinc.com
E-Mail: mail@abtoolsinc.com

Prices Effective 1/1/2018

